

15B

Low-Mid Frequency Transducer

B SERIES



FEATURES

- » Low-Mid frequency 15" cone loudspeaker
- » 1000 W program power handling
- » 4" voice coil
- » Ceramic magnetic structure
- » Centre pole piece and side slot convection cooling (C.A.F.)

SPECIFICATIONS

AES RMS (Average) Power Handling^a:	500 W
Program Power Handling^b:	1000 W
Peak Power Handling^c:	2000 W
Sensitivity:	101 dB SPL, 1W/1m
Nominal Impedance:	8 Ω
Nominal Frequency Range:	45 Hz - 4 kHz
Voice Coil:	Al, edgewound
Voice Coil Diameter:	102 mm (4 in)
Cooling:	C.A.F. (Controlled Air Flow), pole piece and side slot convection
Frame:	Cast aluminium
Spider:	Double
Diaphragm:	Curved
Magnetics:	Anisotropic Barium Ferrite
Flux Density:	1.13 T
Input Connection:	Push terminals, 4 mm diameter
Polarity:	Positive voltage to red terminal moves diaphragm forward
Recommended Baffle Cutout Diameter:	359 mm
Weight:	10.2 kg (22.3 lbs)
Shipping Weight:	11.2 kg (24.5 lbs)

DESCRIPTION

The D.A.S. 15B is a high efficiency 15" diameter cone loudspeaker with 4" diameter voice coil.

It features C.A.F. (Controlled Air Flow), which conjugates centre pole piece and side slot convection cooling to provide high power handling and low power compression.

Exclusive curing techniques are utilized to create an indestructible bond between the copper voice coil and its fibre-glass based support.

The computer designed injected aluminium basket supplies rigidity and mechanical grounding.

A double spider configuration is used for excursion control at high power levels.

APPLICATIONS

Low-mid. Suitable for high power mid-high enclosures.

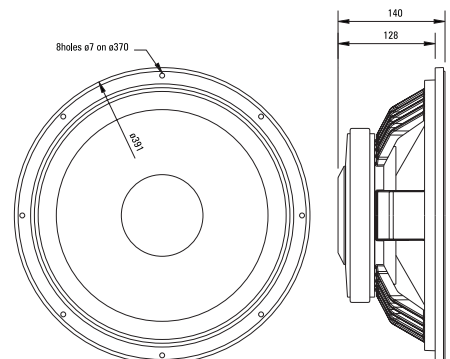

ALL DIMENSIONS IN MILLIMETERS

^a Based on a 2 hour test continuously applying 6 dB crest factor pink noise bandlimited to 50-500 Hz.
^b Conventionally 3 dB higher than the average measure.
^c Corresponds to the signal crests for the test described in ^a.

D.A.S.
Speakers

Frequency Response

Figure 1 shows the on-axis (black) and 45-degree (grey) frequency response at 1 m of a unit flush on a measurement baffle and radiating to an anechoic environment and driven by a 2.83 V swept sine signal.

Impedance

Figure 2 shows impedance with frequency of a unit suspended in free air.

Distortion

Figure 3 shows the Second Harmonic Distortion (grey) and Third Harmonic Distortion (dotted) curves for unit mounted on the measurement baffle and driven at 10% of its power handling.

NOTES. 1.Frequency response: referred to 1 m; low-end obtained through the use of near field techniques; the large measurement baffle provides results akin to mounting the speaker in a diffraction free closed box with internal volume of 320 litres or larger. 2.In practice, cable and connector impedance need to be added. 3.Harmonic distortion components are not plotted beyond 20 kHz.

Product improvement through research and development is a continuous process at D.A.S. Audio. All specifications subject to change without notice.

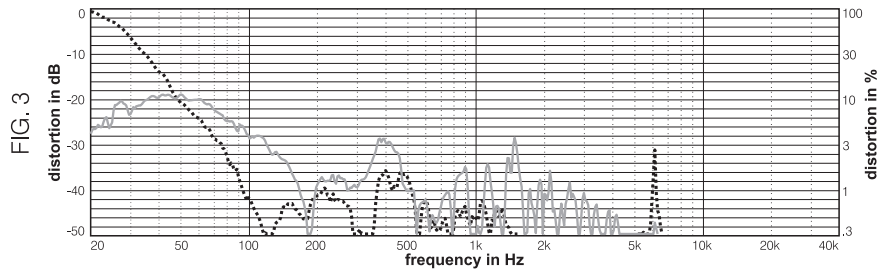
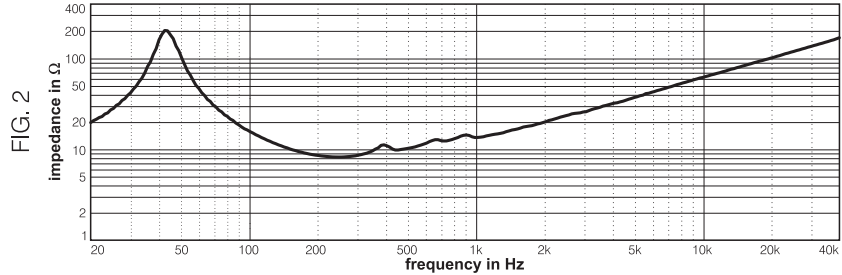
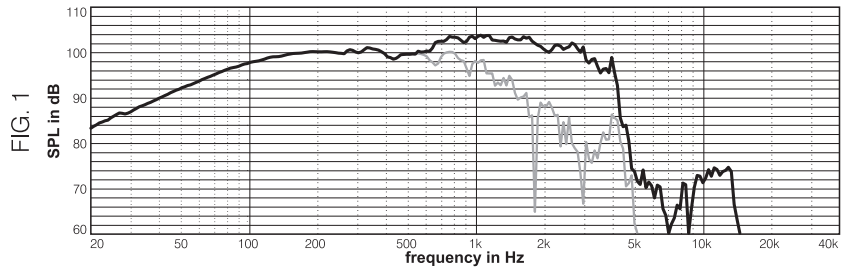

THIELE-SMALL PARAMETERS

Small-Signal

F_s : 42 Hz

Q_{ts} : 0.237

Q_{es} : 0.246

Q_{ms} : 6.386

η_0 : 5.91 %

V_{as} : 198 litres

R_g : 5.6 Ω

S_D : 0.086 m²

(Preconditioning : 1 hour, AES power test at -3dB rated power)

Large-Signal

X_{max} : 4 mm (0-pk)^{XM}

V_D : 0.344 dm³ (0-pk)

^{XM} Calculated as $(H_{vc} + H_{ag})/2 + H_{ag}/4$

ADDITIONAL DATA

Effective piston diameter: 331 mm

M_{ms} : 75 gr

C_{ms} : 189 μ m/N

Voice coil diameter: 102 mm

Voice coil winding depth, H_{vc} : 12 mm

Voice coil length: 23.7 m

Top plate thickness at voice coil, H_{ag} : 8 mm

Displacement limit: 20 mm (pk-pk)

Minimum impedance: 6.0 Ω at 247 Hz

BL: 21.3 T.m

Spider suspension: polycotton

Surround suspension: polycotton

Voice coil support: GFRP (glass fibre reinforced polymer)

D.A.S. Audio, S.A.

C/ Islas Baleares, 24 - 46988 Fuente del Jorro - Valencia, SPAIN

Tel. 96 134 0525 - Tel. Intl. +34 96 134 0860 - Fax. 96 134 0607 - Fax. Intl. +34 96 134 06 07

D.A.S. Audio of
America, Inc.

Sunset Palmetto Park 6816 NW 77th Court, Miami, FL
33166, U.S.A. Tel. 305 436 0521 - Fax. 305 436 0528

<http://www.desaudio.com>