

Frontplattenausschnitt (Rueckseite)
Panel cut out (rear side)

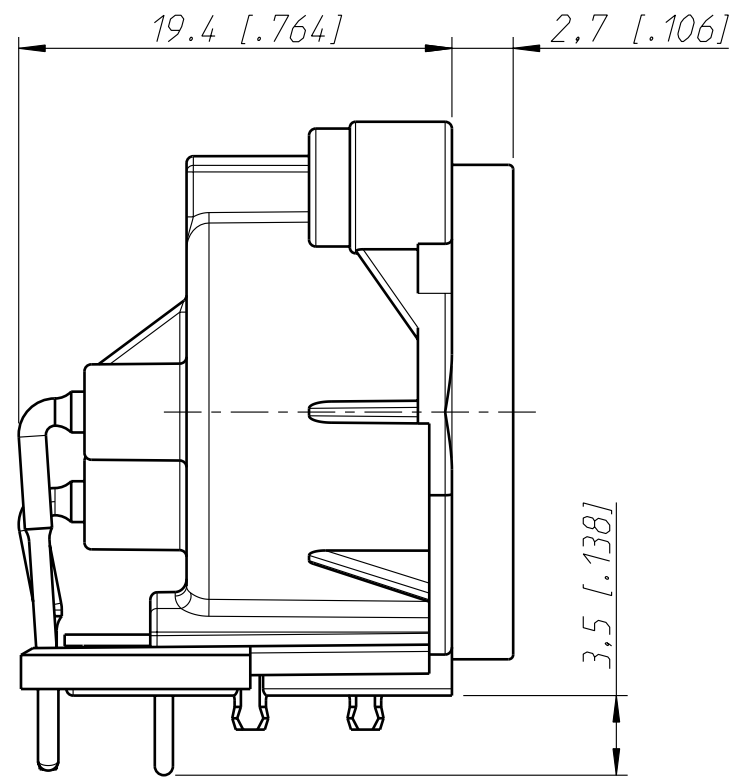

Print Bohrplan (Bestueckungsseite)
PCB-Layout (component side)

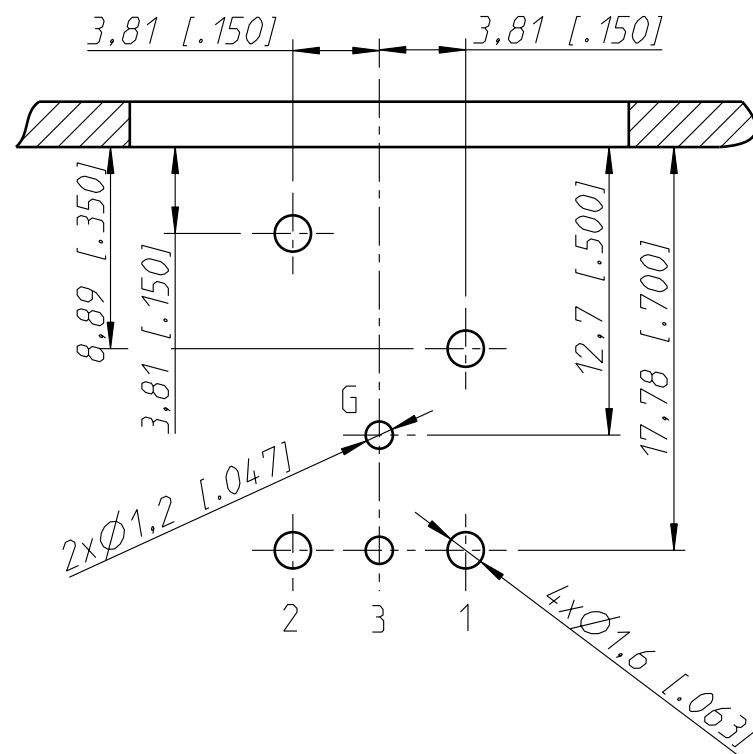
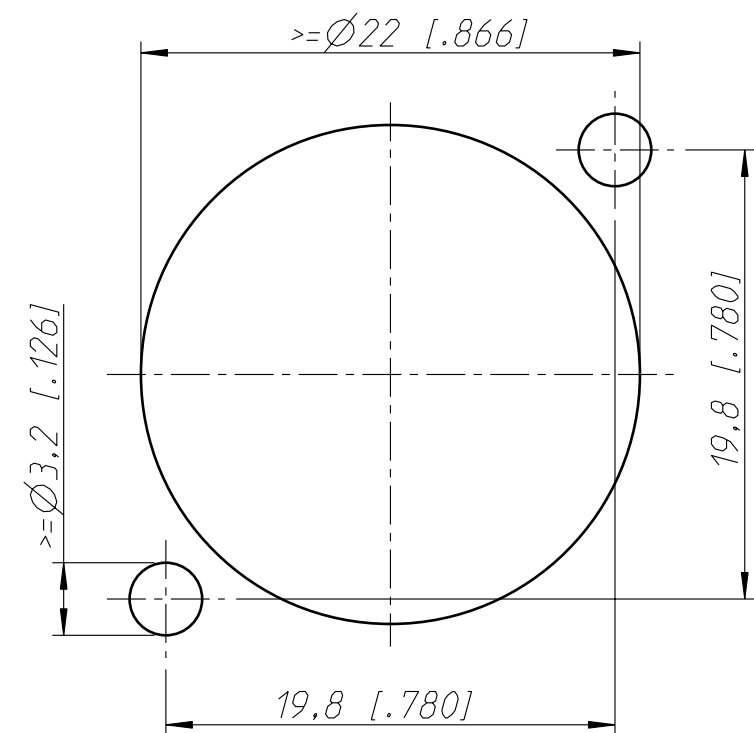
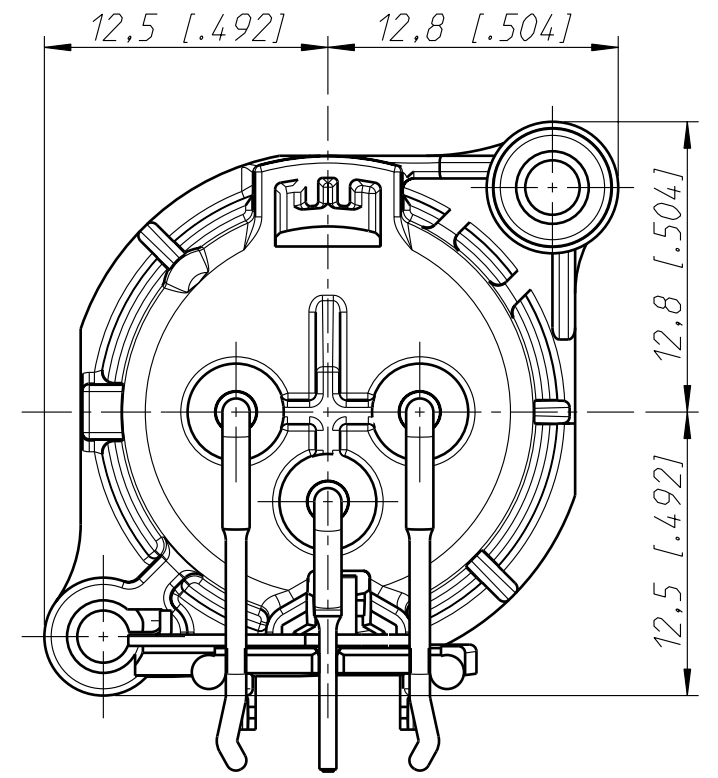

Housing material: UL94 V-0

| Allgemeintoleranzen ISO 2768-m | Werkstoff | Massstab: | Datum | Name |
|---|------------------|-------------|--------------|-----------------------|
| Zeichnung urheberrechtlich geschuetzt (DIN 34) (C) | - | 3:1 (A3) | Gezeichnet | 21.12.93 Dobler |
| | | | Freigegeben | |
| Benennung | NC3MAH NC3MAH | | Geändert | 13.01.10 Mijatovic |
| | | | Aend.-Nr. | - |
| | | | Ersatz fuer: | Blatt 1 von 1 Bl. |
| NEUTRIK AG FL-9494 SCHAAN | | | Zeichn. Nr. | ST-NC3MAH |