

[®]
MACKIE

HR626 HIGH RESOLUTION ACTIVE STUDIO MONITOR OWNER'S MANUAL

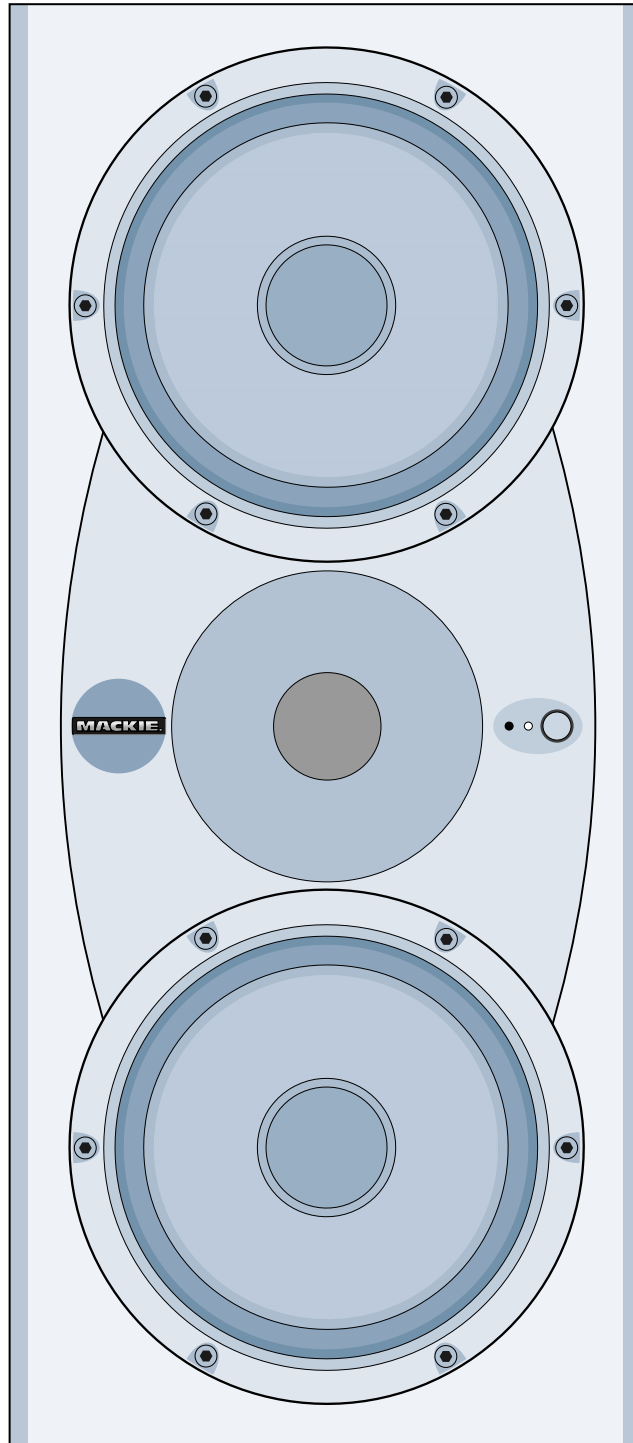

<div style="display: inline-block; text-align: center;"> <p>CAUTION AVIS</p> <p>RISK OF ELECTRIC SHOCK DO NOT OPEN</p> <p>RISQUE DE CHOC ELECTRIQUE NE PAS OUVRIR</p> </div>
<p>CAUTION: TO REDUCE THE RISK OF ELECTRIC SHOCK DO NOT REMOVE COVER (OR BACK) NO USER-SERVICEABLE PARTS INSIDE REFER SERVICING TO QUALIFIED PERSONNEL</p> <p>ATTENTION: POUR EVITER LES RISQUES DE CHOC ELECTRIQUE, NE PAS ENLEVER LE COUVERCLE. AUCUN ENTRETIEN DE PIECES INTERIEURES PAR L'USAGER. CONFIER L'ENTRETIEN AU PERSONNEL QUALIFIE.</p> <p>AVIS: POUR EVITER LES RISQUES D'INCENDIE OU D'ELECTROCUTION, N'EXPOSEZ PAS CET ARTICLE A LA PLUIE OU A L'HUMIDITE</p>

The lightning flash with arrowhead symbol within an equilateral triangle is intended to alert the user to the presence of uninsulated "dangerous voltage" within the product's enclosure, that may be of sufficient magnitude to constitute a risk of electric shock to persons.

Le symbole éclair avec point de flèche à l'intérieur d'un triangle équilatéral est utilisé pour alerter l'utilisateur de la présence à l'intérieur du coffret de "voltage dangereux" non isolé d'ampleur suffisante pour constituer un risque d'électrocution.

The exclamation point within an equilateral triangle is intended to alert the user of the presence of important operating and maintenance (servicing) instructions in the literature accompanying the appliance.

Le point d'exclamation à l'intérieur d'un triangle équilatéral est employé pour alerter les utilisateurs de la présence d'instructions importantes pour le fonctionnement et l'entretien (service) dans le livret d'instruction accompagnant l'appareil.

SAFETY INSTRUCTIONS

1. Read Instructions — All the safety and operation instructions should be read before this Mackie product is operated.
2. Retain Instructions — The safety and operating instructions should be kept for future reference.
3. Heed Warnings — All warnings on this Mackie product and in these operating instructions should be followed.
4. Follow Instructions — All operating and other instructions should be followed.
5. Water and Moisture — Do not place water, hot or chilled drinks on top of this Mackie Product as it may cause a shock hazard. This Mackie product should not be used near water; for example, near a bathtub, washbowl, kitchen sink, laundry tub, in a wet basement, near a swimming pool, swamp, or salivating St. Bernard dog, etc.
6. Cleaning — Clean only with a dry cloth.
7. Ventilation — This Mackie product should be situated so that its location or position does not interfere with its proper ventilation. For example, the Component should not be situated on a bed, sofa, rug, or similar surface that may block any ventilation openings, or placed in a built-in installation such as a bookcase or cabinet that may impede the flow of air through ventilation openings.
8. Heat — This Mackie product should be situated away from heat sources such as radiators or other devices which produce heat.
9. Power Sources — This Mackie product should be connected to a power supply only of the type described in these operation instructions or as marked on this Mackie product.
10. Power Cord Protection — Power supply cords should be routed so that they are not likely to be walked upon or pinched by items placed upon or against them, paying particular attention to cords at

plugs, convenience receptacles, and the point where they exit this Mackie product.

11. Object and Liquid Entry — Care should be taken so that objects do not fall into, and liquids are not spilled into this Mackie product.

12. Damage Requiring Service — This Mackie product should be serviced only by qualified service personnel when:

- A. The power-supply cord or the plug has been damaged; or
- B. Objects have fallen, or liquid has spilled into this Mackie product; or
- C. This Mackie product has been exposed to rain; or
- D. This Mackie product does not appear to operate normally or exhibits a marked change in performance; or
- E. This Mackie product has been dropped, or its chassis damaged.

13. Servicing — The user should not attempt to service this Mackie product beyond those means described in this operating manual. All other servicing should be referred to the Mackie Service Department.

14. To prevent electric shock, do not use this polarized plug with an extension cord, receptacle or other outlet unless the blades can be fully inserted to prevent blade exposure.

Pour prévenir les chocs électriques ne pas utiliser cette fiche polarisée avec un prolongateur, un prise de courant ou une autre sortie de courant, sauf si les lames peuvent être insérées à fond sans laisser aucune partie à découvert.

15. Grounding or Polarization — Precautions should be taken so that the grounding or polarization means of this Mackie product is not defeated.

16. Power Protection — Unplug this Mackie product during lightning storms or when unused for long periods of time. Note that this Mackie product is not completely disconnected from the AC mains service when the power switch is in the OFF position.

17. This apparatus does not exceed the Class A/Class B (whichever is applicable) limits for radio noise emissions from digital apparatus as set out in the radio interference regulations of the Canadian Department of Communications.

ATTENTION — Le présent appareil numérique n'émet pas de bruits radioélectriques dépassant les limites applicables aux appareils numériques de class A/de class B (selon le cas) prescrites dans le règlement sur le brouillage radioélectrique édicté par les ministere des communications du Canada.

WARNING — To reduce the risk of fire or electric shock, do not expose this appliance to rain or moisture.



• Please write the serial number for your studio monitor here (all studio monitors if you have more than one) for future reference (i.e., insurance claims, tech support, return authorization, etc.):

Monitor 1

Monitor 2

Monitor 3

Purchased at: _____

Date of Purchase: _____

Lend Me Your Ears



Exposure to extremely high noise levels may cause permanent hearing loss. Individuals vary considerably in susceptibility to noise-induced hearing loss, but nearly everyone will lose some hearing if exposed to sufficiently

intense noise for a period of time. The U.S.

Government's Occupational Safety and Health Administration (OSHA) has specified the permissible noise level exposures shown in this chart.

According to OSHA, any exposure in excess of these permissible limits could result in some hearing loss. To ensure against potentially dangerous exposure to high sound-pressure levels, it is recommended that all persons exposed to equipment capable of producing these levels use hearing protectors while this unit is in operation. Ear plugs or protectors in the ear canals or over the ears must be worn when operating this amplification system in order to prevent a permanent hearing loss if exposure is in excess of the limits set forth here.

Duration Per Day In Hours	Sound Level dBA, Slow Response	Typical Example
8	90	Duo in small club
6	92	
4	95	Subway Train
3	97	
2	100	Very loud classical music
1.5	102	
1	105	Patrice screaming at Ron about deadlines
0.5	110	
0.25 or less	115	Loudest parts at a rock concert

The HR626 can produce a maximum SPL of 118 dB @ 1m

INTRODUCTION

Thank you for choosing Mackie Designs' HR626 Studio Monitors. We realize that monitors are a critically important tool whether your application is studio recording, audio/video post production, hi-fi, or home theater. Knowing this, Greg Mackie had a simple mandate: Design a reference monitor with a degree of accuracy and versatility unmatched by any other in its size and price category — or any size and price category for that matter. The mandate was simple, but accomplishing it was another story!

Investments in Excellence...

To accomplish the task at hand, Greg and the New Product Development team realized that a commitment was required in terms of new resources and new equipment. So we recruited some of the best speaker and acoustic engineers in the industry to assist in the design of our first studio monitor, the HR824. And we invested in some advanced (and need we say expensive) measurement and analysis tools for the design team to use.

The result? The HR824 Studio Monitors, and their siblings the HR624 and HR626, are extremely accurate and versatile, loaded with unique controls that allow you to fine-tune the sound to match your individual environment precisely. You're gonna love these!

What are they? The Advantages...

The HR626 Studio Monitors are high-resolution, two-way, bi-amplified, active monitors employing a 6th-order Butterworth system with a built-in rear-firing mass-loaded passive radiator. Whew! There are many benefits to integrating an active crossover, power amplifiers, and drivers into a single cabinet, and we've taken full advantage of these benefits in the design of the HR626.

- The crossover point is designed so that the high and low frequency drivers are fed only the frequencies they are best able to reproduce.
- The amplifiers are designed to provide maximum acoustic output from the speakers, yet minimize the danger of speaker damage due to overdriving.
- In addition, the amplifiers' gain and frequency responses are individually hand-trimmed to compensate for typical manufacturing tolerances between the drivers and produce a smooth frequency response from 42Hz to 20kHz (± 1.5 dB).
- The connecting wire between the amplifier outputs and the drivers are kept to an absolute minimum, so the damping factor of the amplifier isn't compromised by the resistance of long speaker cables.

- The acoustic sum of the outputs from the drivers are optimized electronically, as well as physically, so the amplitude response is unity and the phase difference is minimal.

In short, all the complex interconnected components in the system are designed to work in harmony with each other to produce the best possible sound.

The Transducers...

The monitors feature two 6.7-inch die-cast aluminum frame woofers and a 1-inch viscous edge-damped aluminum-alloy dome tweeter on the front, and a 6-inch x 9-inch elliptical flat piston passive radiator in the back.

The high-frequency driver is mounted on a massive, acoustically non-resonant die-cast zinc exponential waveguide, centered between the two low-frequency drivers, which results in wide, controlled dispersion of high-frequency sounds. The unique passive radiator design

provides a smooth response down to 42Hz — an astounding accomplishment for a cabinet of this size! And since the radiator is producing most of the sound at the lowest frequencies, there is very little distortion from the woofer because its cone movement is minimal at those frequencies.

The Cabinet...

The cabinet is made of black oak veneered MDF wood. Two internal “H” braces further increase the strength and rigidity (stiffness) of the box. An open-cell adiabatic foam material fills the inside of the box to absorb internal reflections and dampen standing waves.

Power Amplifiers...

The low-frequency amplifier produces up to 100 watts continuous before clipping, while the high-frequency amplifier produces up to 40 watts continuous.

QUICK START



We realize that you can't wait to hook up your new Mackie Designs HR626 High Resolution Studio Monitors and try them out.

Nevertheless, please take the time to read this page NOW, and the rest can wait until you're good and ready.



Make sure the Voltage Selector Switch 12 on the bottom of the cabinet is set to the correct voltage setting for your AC Mains supply.

Each of the HR626 cabinets has its own built-in power amplifiers. That's right, two amplifiers per speaker cabinet; one for the high-frequency tweeter and one for the low-frequency woofers. You should turn the INPUT SENSITIVITY 2 control on the back of the cabinet down (fully counterclockwise) before turning on the Studio Monitors for the first time. Also be sure to set the mute switch 9 on the front panel to its standby position (in). This will prevent you from accidentally connecting a hot signal source to the monitors and getting a rude surprise.

There are a number of other settings you can make on the back of the HR626, and you can look at the graphic instructions relating to each of them on the back of the cabinet (or wait until you read about them later on in this manual so you really know what they do). For now, just leave them at the factory default set-

tings (ACOUSTIC SPACE = WHOLE; LOW FREQ = 40Hz; HIGH FREQ = 0), except for the POWER MODE 6 switch. Be sure it is set to the STANDBY position.

1. Connect the line-level monitor signal from your mixer, preamp, or other signal source to the SIGNAL INPUT 1 jack on the HR626 Studio Monitor (1/4-inch PHONE, XLR, or RCA).
2. Connect the supplied AC power cord to the IEC socket 7 on the back of the monitor. Plug the other end into an AC outlet properly configured with the voltage corresponding to the Voltage Selector Switch 12 setting.
3. Set the POWER MODE 6 switch on the rear panel to the ON position. With the front panel mute switch 9 depressed, the power amplifier is in Standby mode.
4. Start your signal source (tape deck, CD, DAW, or whatever), but leave the master volume control on your mixer or preamp down.
5. Set the mute switch 9 on the front of the HR626 to the OUT position. The green power 10 LED will turn on.
6. Slowly turn up the INPUT SENSITIVITY 2 control on the back of the monitor to its fully clockwise position (NORMAL).
7. Adjust the master volume on your mixer to a comfortably loud listening level. Enjoy the silky smooth highs and authoritative, commanding lows of the HR626. Then read the rest of this manual.

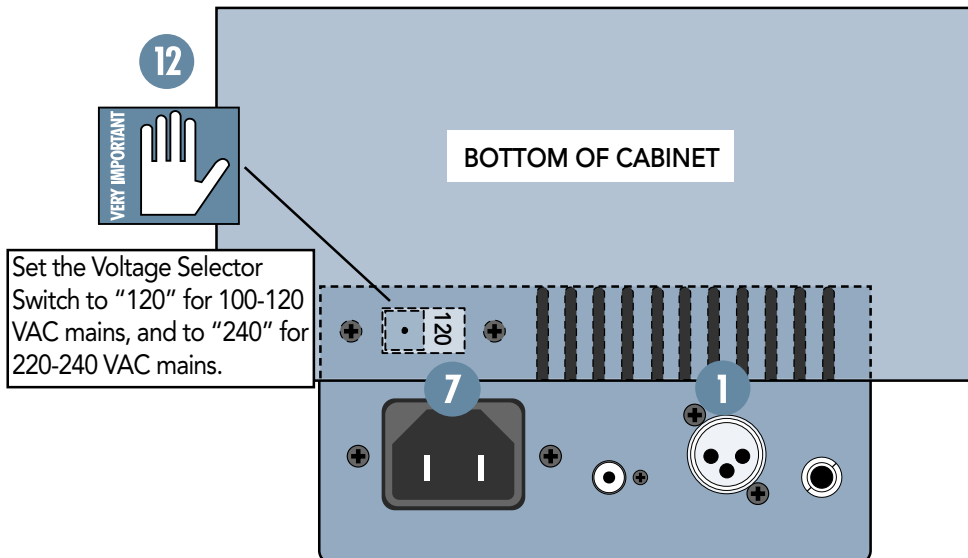
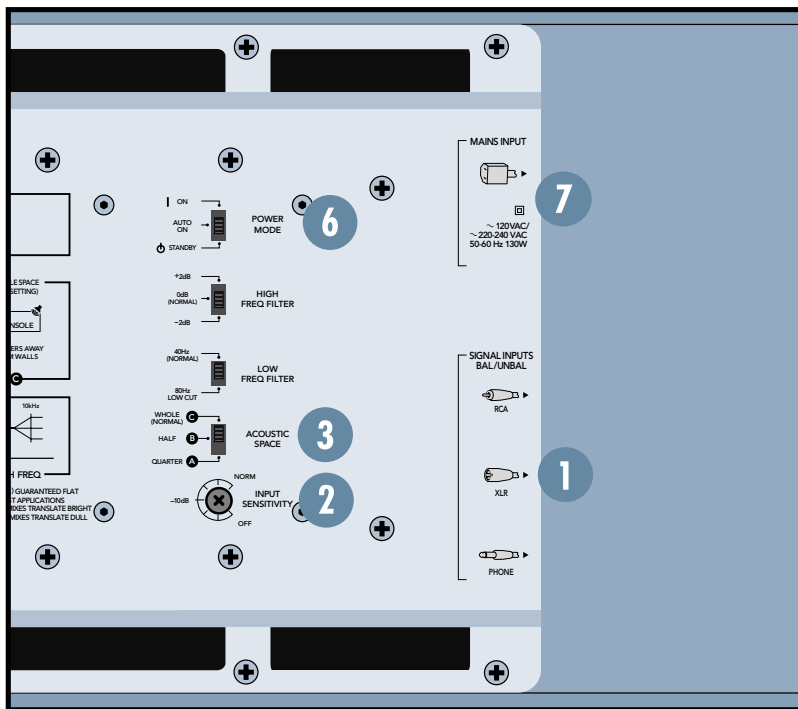
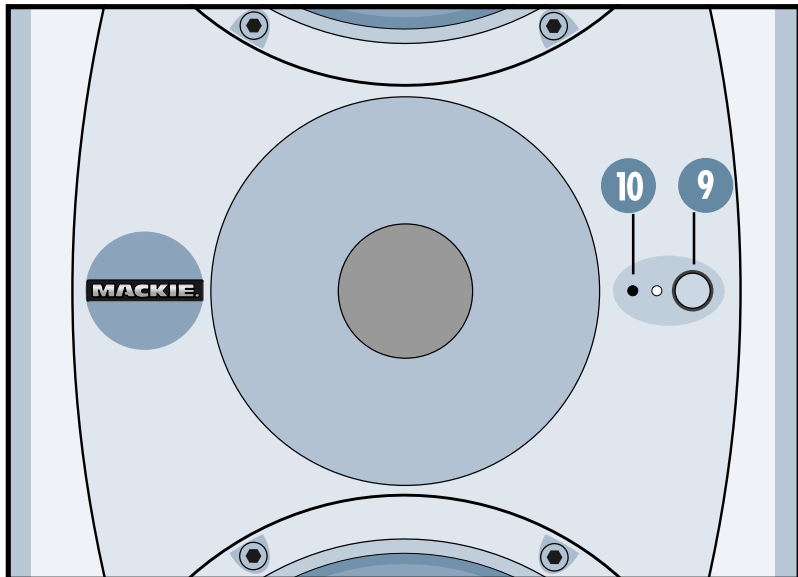

AN EXTREMELY IMPORTANT NOTE ON HR626 BASS RESPONSE AND YOUR CONTROL ROOM



Your new HR626s achieve their best bass response in a room that's optimized for bass reproduction. A lot of factors can conspire to thwart the HR626s' extended low frequency—including room shape, room volume and acoustical treatment.

This is not a cop-out or an apology. It's plain old physics in action. Luckily we've armed you with some compensating controls which you can use to optimize the frequency response of the speakers in your particular room. Consider the following:

The ACOUSTIC SPACE switch must be set correctly

When you put your HR626s in a corner or up against walls, their bass characteristics change. Adjust the ACOUSTIC SPACE 3 switch setting accordingly to avoid muddy or exaggerated low frequency response.

Feel free to experiment

In many respects, every room is unique in terms of its acoustics.

Even after you've read about how to set the HR626's rear panel switches, try other settings to see if your particular room environment requires different adjustments.

And, even after you've placed your monitors where you *think* they'll sound best, try moving them around. You might be pleasantly surprised.

Finally, keep an open mind about improving your room's acoustics and bass-handling ability

Nobody likes to buy a new set of monitor speakers and then be told that they should spend extra bucks on bass traps or a remodeling

job. But the simple fact is, "standard" rooms, i.e. rectangular rooms in conventional business or residential structures, are rarely if ever conducive to optimal low bass reproduction without some modifications.

Luckily, there are plenty of options short of building a new control room, many of which are covered in this manual.

Additional Tidbits of Wisdom

- When you shut down your equipment, turn off the HR626 studio monitors first to prevent thumps and other noises generated by any upstream equipment from coming out the speakers. When powering up, turn on the monitors last.
- Save the shipping box! You may need it someday, and you don't want to have to pay for another one.
- Save your sales receipt in a safe place.
- Also record all HR626 serial numbers in the space provided on the inside front cover, along with where and when you bought them.

Placement

The HR626s were designed to be placed in either a horizontal or vertical position, and can be used in either position for virtually any application. For example, when using the HR626 as a center speaker, you might position the speaker horizontally above or below your video screen. When using as left and right front or rear speakers, you might position the speakers vertically.

Note: The Mackie logo can be rotated 90° so that it is oriented correctly when placing the speakers either vertically or on their sides. Gently pull out on the Mackie emblem, rotate it, and push it back into place.

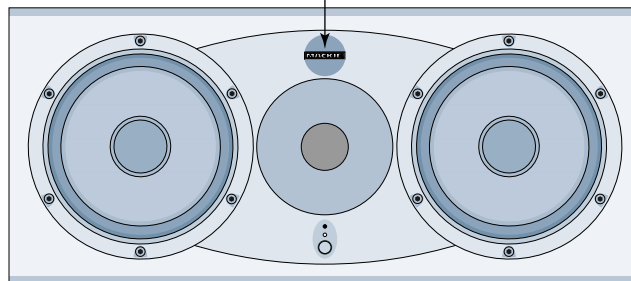

Figure 1. Horizontal Placement

A Few Words About THX™ pm3™ Certification

Nearly two decades ago, George Lucas turned a passion for great sound into the world's most accepted and trusted solution for achieving it. The standard was named THX (for Tomlinson Holman, who developed the THX Sound System when he was the research and technical director at Lucasfilm Ltd.™ in the early 80s), and today, with hundreds of thousands of home theater customers and more than 3000 THX Certified movie theaters enjoying its benefits, the THX name has become nothing short of legendary. Simply put: when it comes to premium sound, no other name so closely defines 'quality' for millions of movie-goers and home theater enthusiasts alike.

Today, a new landscape is emerging. A landscape comprised of hundreds of small, professional multi-channel facilities, whose need for differentiation, expert technical and marketing support, and a true, multi-channel standard is becoming a competitive fact of life. Again, THX has a singular solution and this time it's called THX pm3 Certification.

All facilities involved with mixing and/or monitoring of multi-channel material should have the option to use pm3. THX pm3 Certification is ideal for DVD mastering, sweetening, and mixing; and is also perfect for facilities doing work in broadcast, music, or multi-media applications.

HR Series THX pm3 Certification

All of the monitor speakers in Mackie's HR Series line have passed the THX pm3 Certification on the first try with no modifications!

Anyone seeking THX Certification for their studio or striving to maintain THX standards can use the HR626s, or any of the speakers in the HR Series family, and rest assured that their facility is in full compliance.

Contents

SAFETY INSTRUCTIONS	2
INTRODUCTION	3
Lend Me Your Ears	3
QUICK START	4
AN EXTREMELY IMPORTANT NOTE ON HR626 BASS RESPONSE AND YOUR CONTROL ROOM	6
REAR PANEL DESCRIPTION	8
1 SIGNAL INPUTS	8
2 INPUT SENSITIVITY	8
3 ACOUSTIC SPACE	8
4 LOW FREQ FILTER	9
5 HIGH FREQ FILTER	9
6 POWER MODE	10
7 Mains Input	11
8 Passive Radiator	11
FRONT PANEL DESCRIPTION	12
9 Mute Switch	12
11 OL (Overload) LED	12
PROTECTION CIRCUITS	12
Overload Protect	12
Thermal Protect	13
Integrated Magnetic Shielding	13
Input Signal Wiring	13
SERVICE INFO	14
Troubleshooting	14
Repair	15
TECHNICAL INFORMATION	16
Specifications	16
HR626 Block Diagram	18
Colophon	18
Graphs	19



Part No. 0003325 Rev. B 10/02

©2002 Mackie Designs Inc. All Rights Reserved.

REAR PANEL DESCRIPTION

This is where you connect your signal to the monitor, and make adjustments to the frequency response of the speakers to match the monitor's location and your room's environment.



For THX applications, the rear panel switches and controls should be set to the THX positions as indicated in this section.

1 SIGNAL INPUTS

The location of the signal input jacks makes the connectors exit down and not straight out the back of the enclosure. This flush-mount design allows you to place the monitor right up against the wall if desired.

- The XLR female, TRS female (balanced), and RCA female (unbalanced) connectors are included for user convenience.
- Don't connect more than one source to the jacks.
- Unbalanced TS (tip-sleeve) lines can be accommodated via the TRS jack. Make sure the cable terminates with a TS plug (like a guitar plug), or if it's a TRS plug (such as a headphone plug), make sure the ring is tied to the sleeve and that the plug is fully inserted into the jack.
- The XLR and TRS input connectors accept balanced or unbalanced signals. The connectors are wired as follows (per the AES/IEC standard):

	<u>XLR</u>	<u>TRS</u>	<u>RCA</u>
Hot (+)	Pin 2	Tip	Tip
Cold (-)	Pin 3	Ring	—
Shield (Ground)	Pin 1	Shield	Shield

- The HR626s can be used with a home receiver even if the receiver lacks a preamp output by using a speaker-level to line-level signal attenuator. (See page 13 for more information.)

2 INPUT SENSITIVITY

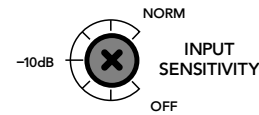

THX = NORMAL

The HR626 expects a line-level signal at its input connectors.

- The reference sensitivity is $-5 \text{ dBu} = 100 \text{ dB SPL}$ at one meter (39 inches) with the INPUT SENSITIVITY control set to its NORMAL position (in other words, wide open).
- The HR626 is designed to operate with a $+4 \text{ dBu}$ signal when the INPUT SENSITIVITY control is in the NORMAL position.
- Refer to the QUICK START section on page 4 for the level-setting procedure.

3 ACOUSTIC SPACE

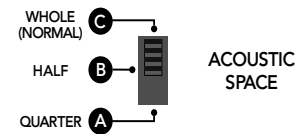

THX = WHOLE (NORMAL)

This is a three-way switch that adjusts the low-frequency response of the speakers to compensate for their placement in the room. See page 5 for an overview of the rear panel.

- If you place the HR626 monitors against a wall (half space **3B**), set the ACOUSTIC SPACE switch to the "B" position. This activates a shelving filter to reduce the low-frequency output by 2 dB to compensate for the half-space placement.
- If you place the monitors into the corners of your room (quarter space **3A**), the low-frequency output approximately doubles from what it is in half space. Set the ACOUSTIC SPACE switch to the "A" position to reduce the low-frequency output by 4 dB to compensate for the quarter-space placement.
- If you use the HR626s free-standing, away from walls and corners (whole space **3C**), set the ACOUSTIC SPACE switch to the "C" position (NORMAL).

4 LOW FREQ FILTER

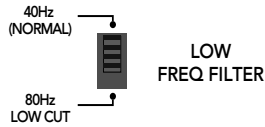

THX = 80Hz

The LOW FREQ FILTER switch inserts a low-frequency rolloff into the response curve.

- For some applications, the low-frequency output of the HR626 may impair your ability to make mix judgements.
- For THX applications, use the 80Hz setting.
- For non-THX applications where a subwoofer isn't enhancing low frequency output use the 40Hz (NORMAL) position.
- The LOW FREQ switch affects the low-frequency content of your mix. Remember how things work in reverse, so removing the deep bass content on playback may actually increase it in the final mix.
- You can use the LOW FREQ switch's 80Hz position to simulate a smaller loudspeaker, especially one with limited low-frequency capability (like a certain popular 2-way nearfield monitor). You may need to do this if a small speaker is the eventual destination of your mix, or perhaps just to see how your mix sounds on a clock radio.

Removing the low-frequency content also allows you to raise the overall output level somewhat. Low-frequency information requires the largest amount of an amplifier's output, so

restricting the low-frequency content allows raising the mid-frequency level somewhat. If your client insists on mixing LOUD, this may be a workable strategy.

5 HIGH FREQ FILTER

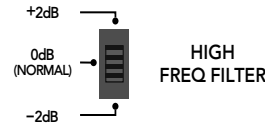

THX = 0 dB

The HIGH FREQ FILTER switch tailors the overall high-frequency response by ± 2 dB beginning at 10kHz. Leave this switch in the 0 (NORMAL) position unless:

- You want to subtly brighten or darken the sound of the speakers.
- Perhaps you have hearing loss caused by too many nights in front of a double Marshall stack.
- You just like to mix on the bright side or dull side.

If your mixes consistently sound dull or dark when you listen elsewhere, this usually indicates that your monitors are too bright, relative to your normal hearing. A bit less high-frequency energy usually fixes this, and you can force the mix in this direction by reducing the high-frequency output of the monitors by using the -2 dB position of the switch.

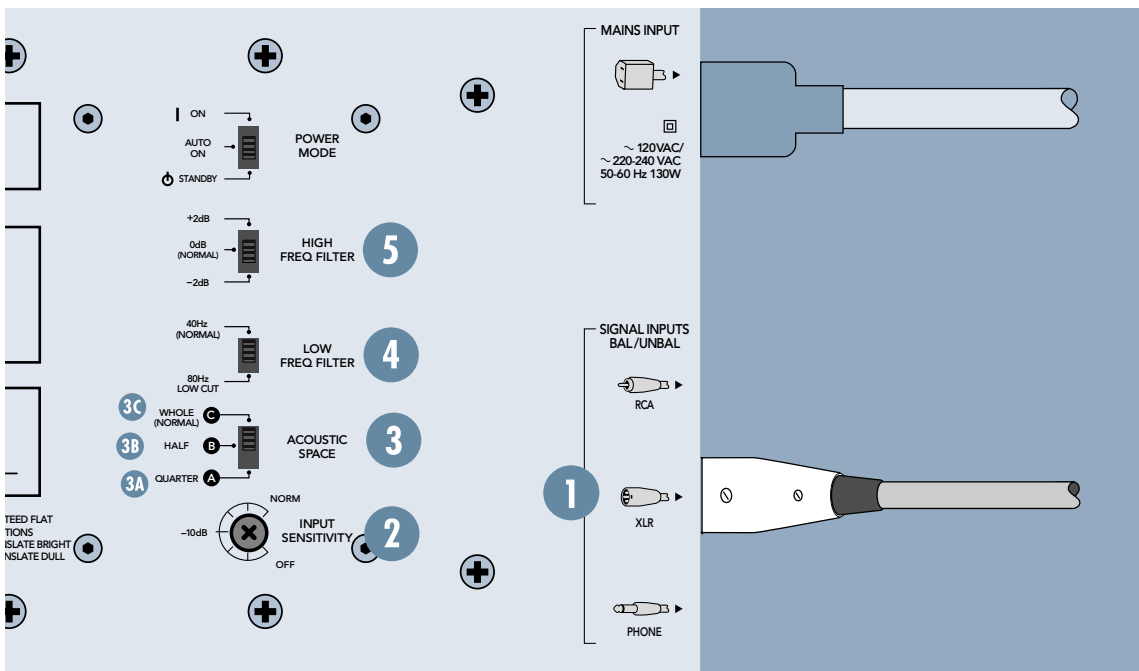

Conversely, if your mixes are consistently too bright, then adding some additional high frequency energy in the monitors satisfies your ears, and the resultant mix has less HF content.



The timbre of your monitors affects the way that your mixes play on other equipment. Remember that the monitors have a mirroring effect on the mix; if the monitors make something too loud in the mix it usually results in not enough of that thing on tape.

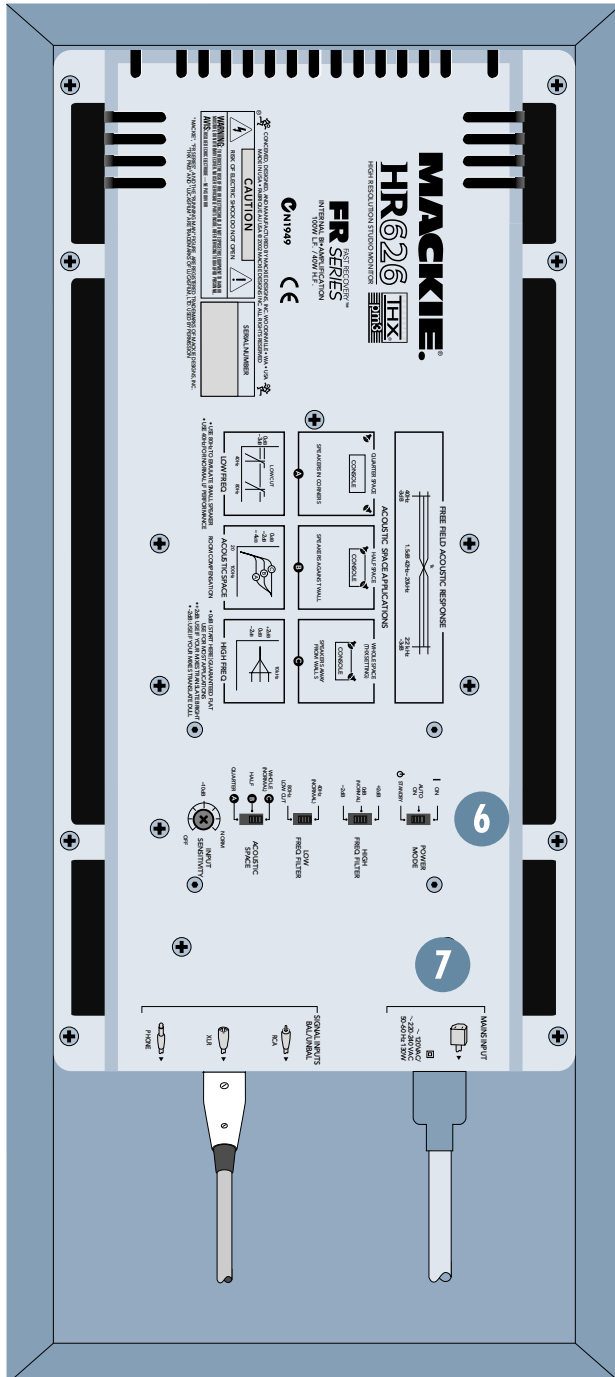

Start with the response modification switches in the factory recommended settings (see Quick Start Section). After prolonged listening, if you notice a trend in your mixes, perhaps making some small adjustments as suggested here will help.

It's a real rush to mix really loud. But remember that the resulting mix only sounds good when you play it at least that loud. However strange it may sound, mixes made at lower levels sound even better when played loud; perhaps even a bit bigger than life.

Get that sound level meter out. Decide what level you're going to mix at and use the meter to help keep your mixing at that level. Your ears will thank you, and your mixes will be better for it.

6 POWER MODE

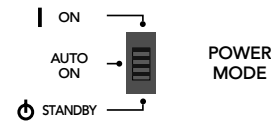

This 3-position switch turns the amplifiers on or off, or sets them to automatic mode. Use this switch to set the HR626s to your preferred mode of operation, and use the front panel mute **9** switch for convenience.

- In the **STANDBY** position, the power amplifiers are in Standby mode and produce no sound. Low-level circuitry is still active, but the power consumption of the circuitry is minimal (12 watts).

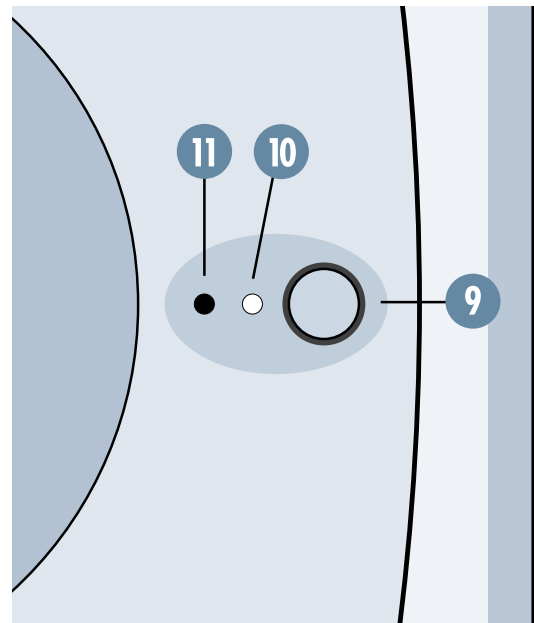

- Flip the switch to the **ON** position and the power amplifiers are live and operate normally. (The front panel mute **9** switch must also be **OUT**.)
- When it's in the **AUTO ON** position, the amplifiers turn on and off depending on the presence or absence of an input signal. An input signal level of -74 dBu (minimum) activates the auto-on function. A silent period greater than eight minutes activates the auto-off function. The green power **10** LED on the front panel reflects the state of the amplifiers.

7 Mains Input

Connect the power cord to this IEC socket, and plug the other end into your AC outlet.

- When the **POWER MODE 6** switch is in the **ON** position (and the mute **9** switch is in the **OUT** position), applying AC power activates the muting circuit for about four seconds while the power supply and internal circuitry stabilize, then the HR626 unmutates and is ready to go.

8 Passive Radiator

When you mount a loudspeaker in a box, there are two things that you can do with the radiation from the rear of the cone: use it to enhance the low-frequency performance of the speaker system (bass reflex system) or soak it up (acoustic suspension system).

- A bass reflex system uses the rear radiation to extend the low-frequency response. Most systems provide holes (ports) in the front or back of the cabinet to release the rear wave. Sometimes the holes have tubes (ducts) in them. The dimensions of the holes and the volume of the cabinet work with the characteristics of the woofer to produce low-frequency extension. These systems are characterized by good low-frequency performance down to the -3 dB frequency set by the design. Below this frequency, the frequency response falls at 24 dB/octave or more.

The HR626 is a bass reflex 6th-order system. Rather than use ports, the vent takes the form of a passive radiator, a mass-loaded flat piston coupled to the air trapped within the enco-

sure. You can't see the passive radiator because it is located at the rear of the cabinet, behind the power amplifier assembly.

- Simple ports or ducts must have sufficient surface area to prevent the velocity of the air within them from exceeding 5% of the speed of sound, which keeps the vent from becoming audible (breathing and wheezing sounds) at high signal levels.
- This requirement for sufficient surface area creates a design problem when using ports — finding enough space in the enclosure for them to fit.

The passive radiator replaces the port found on most speaker systems. It offers several advantages to simple porting:

- One primary advantage of a passive radiator is that it can reproduce low frequencies with lower distortion and at a higher sound pressure level (SPL) than a simple port or duct.
- Our unique passive radiator design uses a flat diaphragm providing exceptional stiffness to the radiating surface.
- The elliptical shape of the passive radiator takes up nearly the entire surface area available on the rear of the enclosure, allowing the passive radiator to move more air than a port.

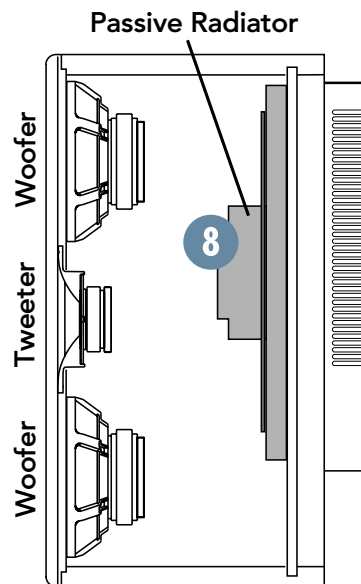

FRONT PANEL DESCRIPTION

9 Mute Switch

Use this switch to turn on or off the HR626 from the front. It works with the POWER MODE 6 switch on the rear panel in the following way:

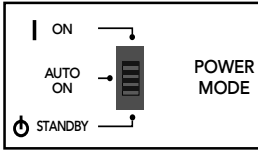

- If the POWER MODE switch on the rear panel is set to STANDBY, the front panel mute 9 switch has no effect. The power 10 LED remains off.
- If the POWER MODE switch is ON, the front panel mute switch turns the HR626 on or returns it to STANDBY mode, as indicated by the power LED (the power LED goes off when muted).
- If the POWER MODE switch is in the AUTO ON position, the front panel mute switch turns the HR626 on as long as there is a signal present.

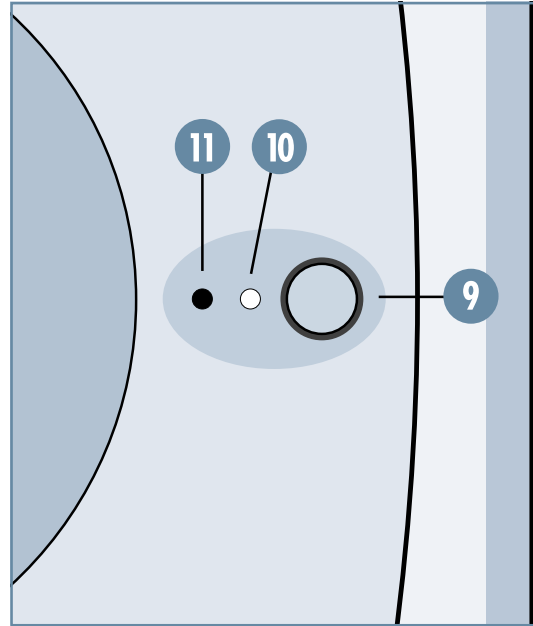

11 OL (Overload) LED

This LED blinks when the overload protection circuit has been triggered.

- Occasional blinking of the OL LED indicates that the loudest transients are reaching the maximum drive capability of the amplifiers. This is okay, although distortion may be audible.
- Frequent or continuous blinking of the OL LED indicates that you have exceeded the maximum drive allowed for the speakers. The amplifiers are clipping, and the overload protection circuit has taken over, reducing the input level. You should reduce the level from your signal source until the OL LED blinks occasionally or not at all.

Overload Protect

- If you see the OL LED blinking more than just occasionally, it's an indication that you should reduce the signal level coming from your mixer or other signal source.
- The blinking OL LED indicates the driver thermal overload protection has activated a compressor. This reduces the input level to the amplifiers.
- The compressor was designed to protect the speakers and its action is highly audible.
- The compressor was not designed for mixing!

PROTECTION CIRCUITS

There are a number of protection mechanisms designed into the HR626 to safeguard the loudspeakers from inadvertent damage.

CAUTION: The protection circuits are designed to prevent damage to the loudspeakers under reasonable and sensible conditions. Should you choose to ignore the warning signs (i.e., frequent Overload LED indications, excessive distortion), you can still damage the speakers in the HR626 by overdriving them past the point of amplifier clipping. Such damage is beyond the scope of the Warranty.



If a client insists on listening to the monitors at a very high volume, you may find that the OL LED lights frequently. Since the majority of the power requirement in any monitor are the low frequencies, selectively reducing the low end can provide a little more headroom and volume for the monitors. Change the LOW FREQ FILTER 4 switch to 80Hz if necessary, to reduce the bass response. This may allow the HR626s to play just enough louder to satisfy the client and to eliminate most of the amplifier clipping.

However, the best solution is to purchase the companion HRS120 or HRS150 powered subwoofer to reinforce the frequencies below 80Hz.

Thermal Protect

All amplifiers produce heat. The HR626 is designed to be efficient both electrically and thermally.

- If for some reason the heatsinks get too hot, a thermal switch activates, placing the HR626 into Standby mode (indicated when the green POWER LED 10 turns off).
- Should this happen, make sure that airflow to the rear of the cabinet is not restricted.
- When the heatsinks cool down to a safe temperature, the switch resets and normal operation resumes.

Integrated Magnetic Shielding

The HR626 Studio Monitor contains drivers with large magnet structures. The drivers' magnets are shielded to help prevent the magnetic field from radiating out into the environment and playing havoc with computer monitors or TV screens. Unshielded speakers can cause distortion in both the shape and color of the picture if placed too close to a CRT (cathode ray tube). If you have a particularly sensitive computer monitor or TV screen, it may be necessary to move the speakers a few inches away.

Input Signal Wiring

You should use high-quality, shielded cable to connect the signal source to the SIGNAL INPUT jack 1 on the HR626.

- Foil shielded cables, such as Belden 8451, 8761, or 9501 are commonly used for studio wiring.
- Microphone cables work well.
- The better the shield, the better the immunity from externally induced noise (like EMI and RFI). Route the cable away from AC power cords and outlets. These are common sources for hum in an audio signal. Wall warts and line lumps are especially insidious hum inducers!

You can purchase quality cables from your Mackie dealer.

- In certain home theater applications, it may be necessary to connect the speaker outputs from a stereo receiver to the inputs of the HR626s, if the receiver doesn't have preamp outputs or other line-level output connections.



CAUTION: Do not attempt to connect a speaker output directly to the input of the HR626! Speaker levels are much higher than line levels and can damage the input circuitry in the HR626.

You can, however, insert a speaker-level to line-level signal attenuator between the receiver's speaker output and the HR626's input. Your Mackie dealer may be able to help you find one, or you can build your own. Contact our tech support department for more information.

SERVICE INFO

Details concerning Warranty Service are spelled out on the Warranty Card included with your monitor (if it's missing, let us know and we'll rush one to you).

If you think your monitor has a problem, please do everything you can to confirm it before calling for service, including reading through the following Troubleshooting section. Doing so might save you from deprivation of your monitor and the associated suffering.

Of all Mackie products returned for service (which is hardly any at all), roughly 50% are coded "CND" — Could Not Duplicate, which usually means the problem lay somewhere else in the system. These may sound obvious to you, but here are some things you can check:

Troubleshooting

No Power

- Our favorite question: Is it plugged in?
- Make sure the power cord is securely seated in the IEC socket **7** and plugged all the way into the AC outlet.
- Make sure the AC outlet is live (check with a tester or lamp).
- Is the mute **9** switch on the front panel in the OUT position *and* the POWER MODE **6** switch on the rear panel in the ON position?
- Is the power **10** LED on the front panel illuminated? If not, make sure the AC outlet is live. If so, refer to "No Sound" below.
- If the power LED is not illuminated, and you are certain that the AC outlet is live, it will be necessary to have the HR626 serviced. *There are no user-serviceable parts inside.* Refer to "Repair" at the end of this section to find out how to proceed.

No Sound

- Is the power **10** LED on the front panel illuminated? If not, refer to "No Power" above.
- Is the INPUT SENSITIVITY **2** control turned up?
- Is the signal source turned up? Make sure the signal level from the mixing console (or whatever device immediately precedes the studio monitor) is high enough to produce sound.

- If it's a stereo pair, try switching them around. For example, if a left output is presumed dead, switch the left and right cords at the monitor end. If the problem switches sides, it's not the monitor. It could be a bad cable, or no signal from the mixer.

Bad Sound

- Is the input connector plugged completely into the jack? If using a ¼" TS or TRS plug, make sure it is plugged all the way in.
- Is it loud and distorted? Reduce the signal level at the mixer.
- If possible, listen to the signal source with headphones plugged into the preamp stage. If it sounds bad there, it's not the monitor.
- Too much bass or not enough bass? Move around the room and see if the bass response changes. It's possible your listening position coincides with a room mode where the low frequencies either become exaggerated or nulled. If so, try moving the monitors to a different position, or moving your listening position.

Noise/Hum/Buzz

- Check the signal cable between the mixer and the monitor. Make sure all connections are secure. These problems usually produce crackling noises, hum, or buzz.
- If connecting an unbalanced output to the HR626 balanced input, make sure the shield is connected to the unbalanced ground of the source *and* to pins 1 and 3 of the XLR (or the sleeve and ring of the TRS jack).
- If a CATV cable is connected to the system, try disconnecting it. If the hum goes away, call your cable carrier to check for proper grounding of the cable.
- Make sure the signal cable is not routed near AC cables, power transformers, or other EMI sources (including wall warts and line lumps!). These sources usually produce hum.
- Is there a light dimmer or other triac-based device on the same AC circuit as the monitor? Dimmers cause buzzing noises. Use an AC line filter or plug the monitor into a different AC circuit.

- Excessive hiss is an indication of an incorrect gain setting somewhere before the speaker.
- If possible, listen to the signal source with headphones plugged in. If it sounds noisy there, it's not the monitor.

I hear sound from the monitors after I switch the AC power off!

- Use the front panel switch to turn the monitors on and off, or turn off the signal going to the monitors when the AC power is turned off.

Repair

Service for the U.S. versions of our monitors is available only from our factory, located in sunny Woodinville, Washington. (Service for monitors living outside the United States can be obtained through local dealers or distributors.) If your monitor needs service, follow these instructions:

1. Review the preceding troubleshooting suggestions. Please.
2. Call Tech Support at 1-800-258-6883, 7 am to 5 pm PST, to explain the problem and request an RA (Return Authorization) number. Have your monitor's serial number(s) ready. You must have an RA number before you can obtain service at the factory.
3. Set aside the power cord, owner's manual, or anything else that you'll ever want to see again. We are responsible for the return of the monitor only.
4. Pack the monitor in its original packing box. This is *very important*. When you call for the RA number, please let Tech Support know if you need new packaging. *Mackie is not responsible for any damage that occurs due to non-factory packaging.*
5. Include a legible note stating your name, shipping address (no P.O. boxes), daytime phone number, RA number, and a detailed description of the problem, including how we can duplicate it.
6. Write the RA number in **BIG PRINT** on top of the box.

7. Ship the monitor to us. We suggest insurance for all forms of cartage. Ship to this address:

Mackie Designs
SERVICE DEPARTMENT
16140 Wood-Red Rd. NE, Suite 5
Woodinville, WA 98072

8. We'll try to fix the monitor in three to five business days. Ask Tech Support for current turnaround times when you call for your RA number. The product **MUST** be packaged in its original packing box and must have the RA number appear on the box. Once it's repaired, we'll ship it back the same way in which it was received. This paragraph does not necessarily apply to non-warranty service.

TECHNICAL INFORMATION

Specifications

Enclosure

Materials and Construction:

5/8-inch (16mm) thick MDF construction with 1-inch (25.4mm) thick MDF front panel with radiused edges to minimize diffraction.

Proprietary die-cast zinc exponential wave guide for controlled, wide dispersion from high-frequency driver.

Two internal "H" braces adds to cabinet stiffness.

Open cell adiabatic "foam fill" acoustical damping material absorbs internal reflections, preventing delayed sound coloration.

Flush-mount connector system allows monitor to be placed against a wall without need for connector clearance.

Transducers

Low-frequency driver:

Number of drivers: 2
Diameter: 6.7 inches (170 mm)
Sensitivity (2.83V, 1 m): 89 dB SPL
Nominal Impedance: 8 Ω
Voice Coil Diameter: 1.25 inches (32 mm)
Power Handling (Long Term/Program): 50/150 watts

Frequency Range: 38Hz to 6kHz
Frame: Die Cast Aluminum
Magnet: Ferrite
Bucking Magnet (Shield): Ferrite

High-frequency driver:

Sensitivity (2.83V, 1m): 91 dB SPL
Nominal Impedance: 6 Ω
Power Handling (Long Term/Program): 20/50 watts
Frequency Range: 1.6kHz to 22kHz
Diaphragm/Suspension: Aluminum/Impregnated Cloth
Voice Coil Diameter: 1.0 inch (25.4mm)
Magnet: Ferrite
Bucking Magnet (Shield): Ferrite

Wave Guide:

Frequency Response: 2.5kHz to 20kHz, ± 2 dB
Mouth Size: 6.13 inches diameter (156 mm)

Horizontal and Vertical Coverage:
120°, $\pm 10^\circ$
3kHz to 20kHz

Passive Radiator:

6-inch x 9-inch (152mm x 228mm) mass-loaded elliptical flat piston with variable thickness filleted edge rubber surround.

Crossover Section

Crossover Type:

Modified Butterworth, 18 dB/octave @ 1.8kHz

Amplifier Section

Low-frequency power amplifier:

Rated Power (at 1kHz with 1% THD): 100 watts
In Japan (100 VAC): 67 watts
Rated Load Impedance: 4 Ω
Slew Rate: 15V/ μ S
Distortion (THD, SMPTE IMD, DIM 100): < 0.035%

Signal-to-Noise

(20Hz-20kHz, unweighted, referenced to 100W into 4 Ω): > 101 dB

Cooling: Convection
Design: Monolithic IC, Class AB, Parametric Servo Feedback

High-frequency power amplifier:

Rated Power(at 1kHz with 1% THD): 40 watts
In Japan (100 VAC): 28 watts
Rated Load Impedance: 8 Ω
Slew Rate: 15V/ μ S
Distortion (THD, SMPTE IMD, DIM 100): < 0.035%

Signal-to-Noise

(20Hz-20kHz, unweighted, referenced to 40W into 8 Ω): > 93 dB

Cooling: Convection
Design: Monolithic IC, Conventional Class AB

System Specifications

Input Type: Balanced Differential (XLR and 1/4" TRS)
Unbalanced (RCA)
Input Impedance: 20k Ω Balanced
10k Ω Unbalanced
Input Protection: RFI and Level Protected
Input Sensitivity: +4 dBu @ 300Hz for full output
+20 dBu
Maximum Input Level: +20 dBu
Low Cut Frequency: 80Hz, 2nd Order, Butterworth
HF Equalization: Shelving ± 2 dB @ 10kHz
Acoustic Space:
A position: -4 dB @ 42Hz, shelving
B position: -2 dB @ 42Hz, shelving
C position: flat
Compressor:
Independent high and low frequency overload detection
Enclosure Alignment: 6th Order
Over Excursion Prevention: 2nd Order High-Pass Filter
Low Line Voltage Shut Down: 67% of Nominal Line
Thermal Protection: Amplifier Shut-Down, Auto Reset
Muting: 5 seconds at turn-on
Signal Sense Threshold: -74 dBu (0.155 mV)
Driver Protection: Compressor with independent LF and HF overload detection

Acoustic Section

Free-Field Frequency Response:

± 1.5 dB, 42Hz to 20kHz

Lower cutoff frequency: -3 dB @ 40Hz

Upper cutoff frequency: -3 dB @ 22kHz

Sound Pressure Level at 1 meter,

-7.5 dBu into balanced input: 100 dB SPL @ 1m

Maximum peak SPL per pair: 118 dB SPL @ 1m

Maximum short term SPL on axis,

half space 80Hz to 2.5kHz: 109 dB SPL @ 1m

Residual noise (maximum gain, 600 Ω source,

20Hz-20kHz bandwidth): < 8 dB SPL @ 1m

Rated Line Input Voltage and Power:

Power consumption:

Standby mode: 12 watts

Quiescent (idle): 20 watts

Musical Program, Loud mix: 105 watts

Both channels driven into
resistive loading to 1% clipping

(LF 86W/4 Ω , HF 38W/8 Ω): 255 watts

US: 120 VAC, 60Hz

Europe: 240 VAC, 50Hz

Korea

(AC Power Selector at 240V): 220 VAC, 60Hz

Japan

(AC Power Selector at 120V): 100 V, 50-60 Hz

Rated Power

(For UL-6500, CSA-E65-94, EN-60065):

130 watts

Physical Properties

Height: 8.8 inches (224 mm)

Width: 19.6 inches (498 mm)

Enclosure Depth: 10.4 inches (264 mm)

Overall Depth: 12.4 inches (315 mm)

Internal Volume: 0.51 cubic feet (14.4 liters)

Weight: 31.0 lbs. (14.1 kg)

Mackie Designs is always striving to improve our products by incorporating new and improved materials, components and manufacturing methods. Therefore, we reserve the right to change these specifications at any time without notice.

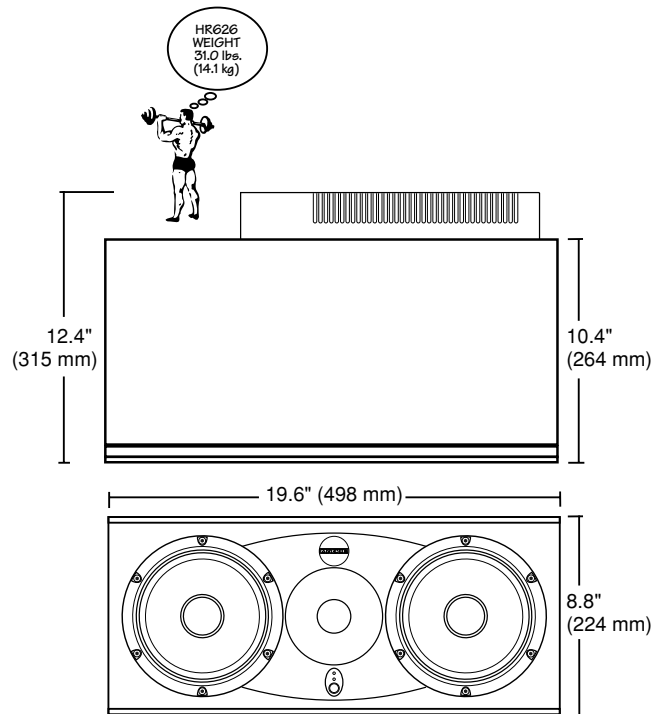

HR626 Block Diagram

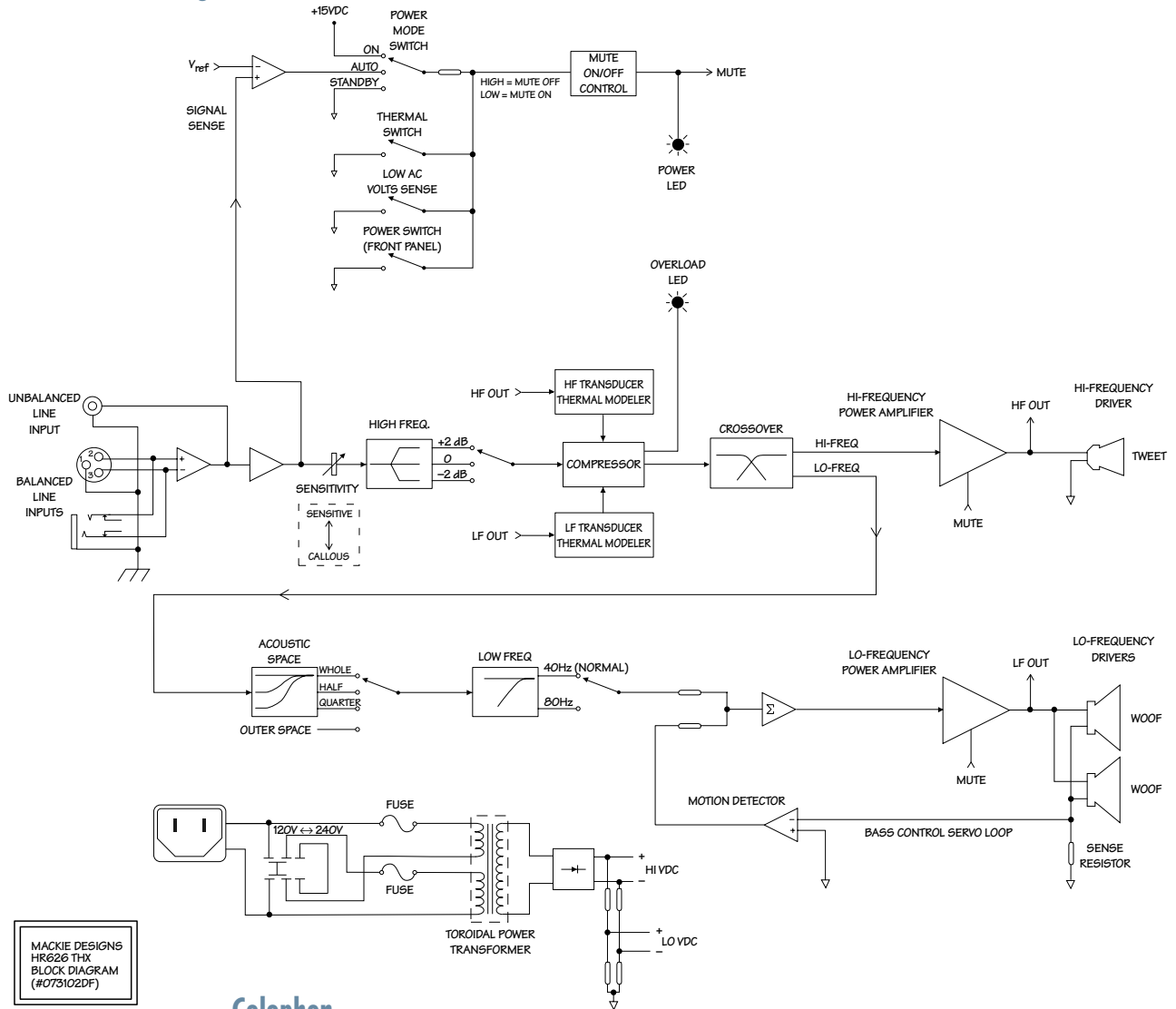

MACKIE DESIGNS
HR626 THX
BLOCK DIAGRAM
(#073102DF)

Colophon

The text is a compilation based on input from a number of sources, including design engineer Cam Jones, acoustic engineer Terry Wetherbee, and audio recording guru Rick Chinn. Dave Franzwa produced this manual using the following tools:

Initially written in Microsoft® Word, the text was imported into Adobe PageMaker®. Illustrations were produced in Adobe Illustrator®. Most of the work was done on a Power Macintosh® G4 with Mac OS 9.1 installed. This machine has a PowerPC G4 processor, 384MB of RAM, a 28.62 GB internal hard drive, and an internal Sony CD-ROM drive. The primary fonts used were ITC Century Light Condensed and Futura Condensed, both from Adobe Systems Incorporated. This entire manual was written and produced at a cluttered desk next to a westward-facing window overlooking Woodinville-Redmond Road while sitting in a comfy chair.

The following are trademarks or registered trademarks of Mackie Designs Inc.: The Mackie logo, HR Series, and the Running Man.

THX pm3 and Lucasfilm are trademarks of Lucasfilm Ltd. Used by permission.

This manual also contains names and marks of other companies which belong to those respective companies, and are hereby acknowledged.

HR626 design protected under the following patent: DES. 387,351

Graphs

HR HIGH RESOLUTION SERIES

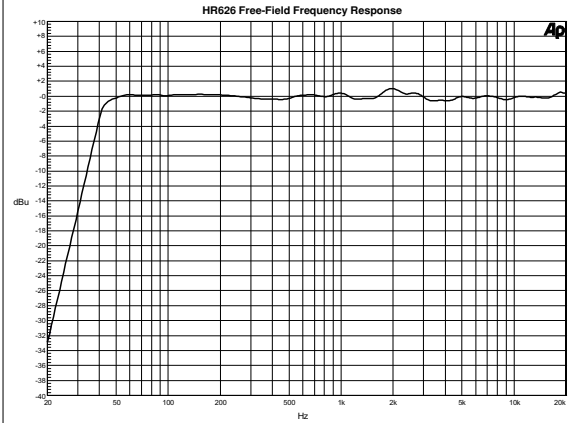
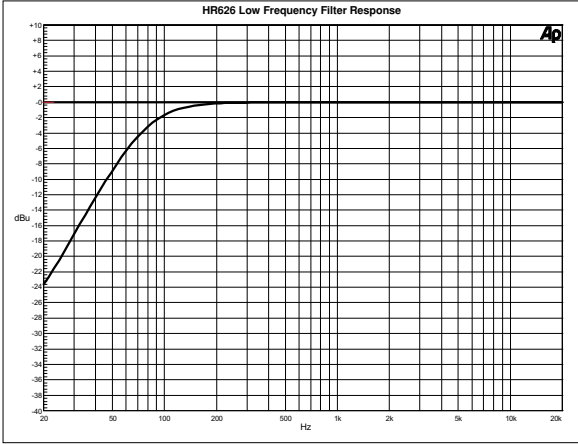
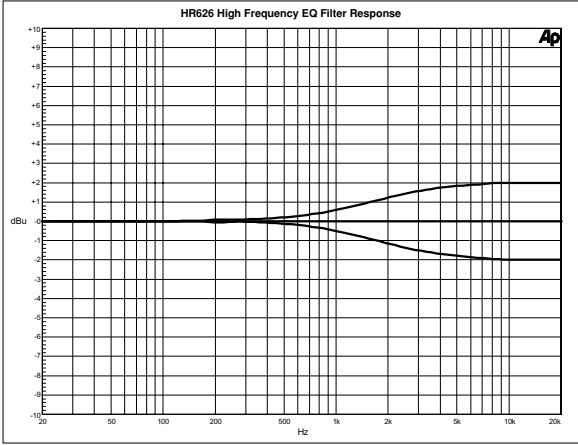
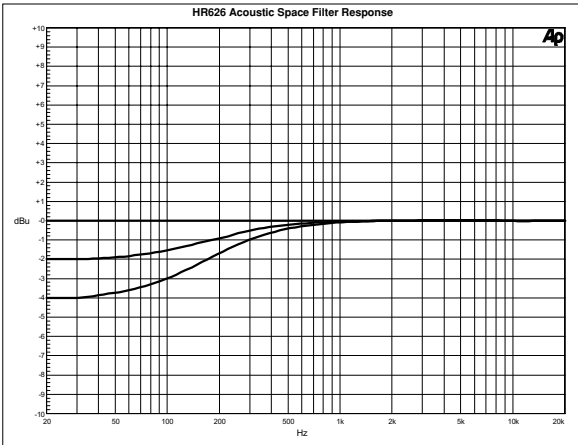



*Some of the
people at our
factory who helped
design, build, sell,
and support your
product.*

MACKIE®

Mackie Designs Inc.

16220 Wood-Red Rd. NE • Woodinville, WA 98072 • USA
US & Canada: 800/898-3211

Europe, Asia, Central & South America: 425/487-4333

Middle East & Africa: 31-20-654-4000

Fax: 425/487-4337 • www.mackie.com

E-mail: sales@mackie.com