

General Description

When the term “graphic equalizer” was first coined, the intent was to provide a device that allowed the user to “draw” the desired frequency response using slider controls on the unit’s front panel. Thus, the Holy Grail of graphic equalizers is a device with a response that truly matches the slider settings. For years, this seemingly unobtainable goal resulted in products based on the fine art of compromise ... until now ... until the DEQ 60.

It’s not Constant – not Proportional – It’s Perfect! Digital Signal Processing (DSP) allows filter technology not possible with analog designs. Rane coined the term **Perfect-Q™** to describe the results (U.S. & international patents filed). The DEQ 60 is the world’s first true graphic equalizer (i.e., one providing real mechanical front panel slide controls) whose

output response precisely matches its front panel settings. Perfect-Q features virtually no band interaction and extremely low ripple between adjacent bands. To keep things flexible, fear not proportional-Q lovers, each channel of the DEQ 60 is selectable between Perfect-Q or Proportional-Q response.

For all the details, read the RaneNote “Perfect-Q, the Next Step in Graphic EQ Design” available at the Rane website.

The DEQ 60 is available in two versions: The DEQ 60 with 25 mm sliders, and the DEQ 60L with 45 mm sliders. The DEQ 60L also features a switchable Cut-Only mode.

The DEQ 60 Graphic Equalizer provides the most complete set of pure EQ functions ever offered in an analog controlled equalizer.

Features

- Perfect-Q™: What You See Is What You Get (**No** filter interaction)
- Proportional-Q: Classic smooth response
- Independent Accelerated-Slope™ 3-band full-cut tone controls
- Low-Cut and High-Cut Filters
- Input and Output Level controls
- Each channel may use A or B channel controls:
 - Stereo Linking
 - Two “analog memories”
 - A-curve / B-curve comparison
- DEQ 60: 25 mm sliders; includes security cover
- DEQ 60L: 45 mm sliders; switchable Cut-Only mode
- Two Boost / Cut ranges: ±6 dB or ±12 dB
- Eight segment metering for each Input **and** Output
- Analog controlled DSP
- XLR, TRS and Euroblock connectors
- Bypass switch (DSP), Bypass relay (power failure)
- Exceptional RF and magnetic immunity
- Universal internal switching power supply

DEQ 60 & DEQ 60L

GRAPHIC EQUALIZERS



Parameter	Specification	Limit	Units	Conditions/Comments
Inputs: Type	Active Balanced			
.....Connectors	XLR, ¼" TRS, Euroblock			XLR pin 2 hot per AES standards
.....Maximum Input	+22	1	dBu	1 kHz
.....Common Mode Rejection	60	typ.	dB	1 kHz
.....Impedance	14.6k	1%	Ω	Each leg to ground @ 1 kHz
DSP Block				
24-bit Converters: Sample Rate	48		kHz	
.....Dynamic Range	106	typ.	dB	A-weighted (input to output); unity
Propagation Delay	1.29	typ.	ms	
Input Level: Range	±12		dB	
Output Level: Range	±12		dB	
Graphic EQ: Bands:	30 ⅓-octave ISO spacing		Hz	25 Hz to 20 kHz
.....Type	Perfect-Q or Proportional-Q			Switchable, each channel
.....Range	±6 or ±12		dB	Switchable, each channel
.....DEQ 60 Slider Travel	25		mm	Center detent=0 dB
.....DEQ 60L Slider Travel	45		mm	Center detent=0 dB
Tone Controls	3-band; Accelerated Slope™			2nd-order, phase 0° @ unity gain
.....Range	+6 to off		dB	Center detent=0 dB
.....Low/Mid Crossover Point	300		Hz	
.....Mid/High Crossover Point	4		kHz	
Low-Cut Filter	15-240		Hz	
High-Cut Filter	5-20		kHz	
Meters	Input and Output			Each channel
.....Type	Peak responding		dBu	Peak-dBu is displayed for 1.5 sec
.....Attack/Decay	0/500	typ.	ms	per 20 dB step
Bypass:Power Failure	Automatic relay bypass			Input wired to Output
Bypass Switch Mode				Each channel
.....Rear switch:Bypass All	Filters and Levels bypassed			By front panel bypass
.....Rear switch:Bypass Filters	Filters bypassed			By front panel bypass
A/B Switches	Determine controls to channel			Bypass and A/B not affected
Outputs:	Active Balanced			
.....Connectors	XLR, ¼" TRS, Euroblock			XLR pin 2 hot per AES standards
.....Impedance	100	1%	Ω	Each leg to ground
.....Maximum Output	+22	1	dBu	600 Ω or greater
EMI Filters	Yes			Inputs and Outputs
Frequency Response	15 Hz to 20 kHz	+0/-3	dB	
THD+Noise	.02	typ.	%	+4 dBu, 20-20 kHz, 20 kHz BW
THD+Noise	.006	typ.	%	+4 dBu, 1 kHz, 20 kHz BW
Crosstalk	<-100	typ.	dB	2 kHz
Power Supply Requirement				100 to 240 VAC, 50/60 Hz, 20 W
Unit: Agency Listing				UL/cUL/CE
Unit: Construction	All Steel			
DEQ 60: Size	3.5" H x 19" W x 5.25" D (2U)			(8.9 cm x 48.3 cm x 13.3 cm)
.....Weight	7.3 lb			(3.3 kg)
.....Shipping: Size	4.5" x 20.3" x 13.75"			(11.5 cm x 52 cm x 35 cm)
.....Weight	12 lb			(5.5 kg)
DEQ 60L: Size	5.25" H x 19" W x 5.25" D (3U)			(13.3 cm x 48.3 cm x 13.3 cm)
.....Weight	11 lb			(5 kg)
.....Shipping: Size	11" x 23" x 16"			(27.9 cm x 58.4 cm x 40.6 cm)
.....Weight	18 lb			(8.1 kg)

Note: 0 dBu=0.775 Vrms

Block Diagram

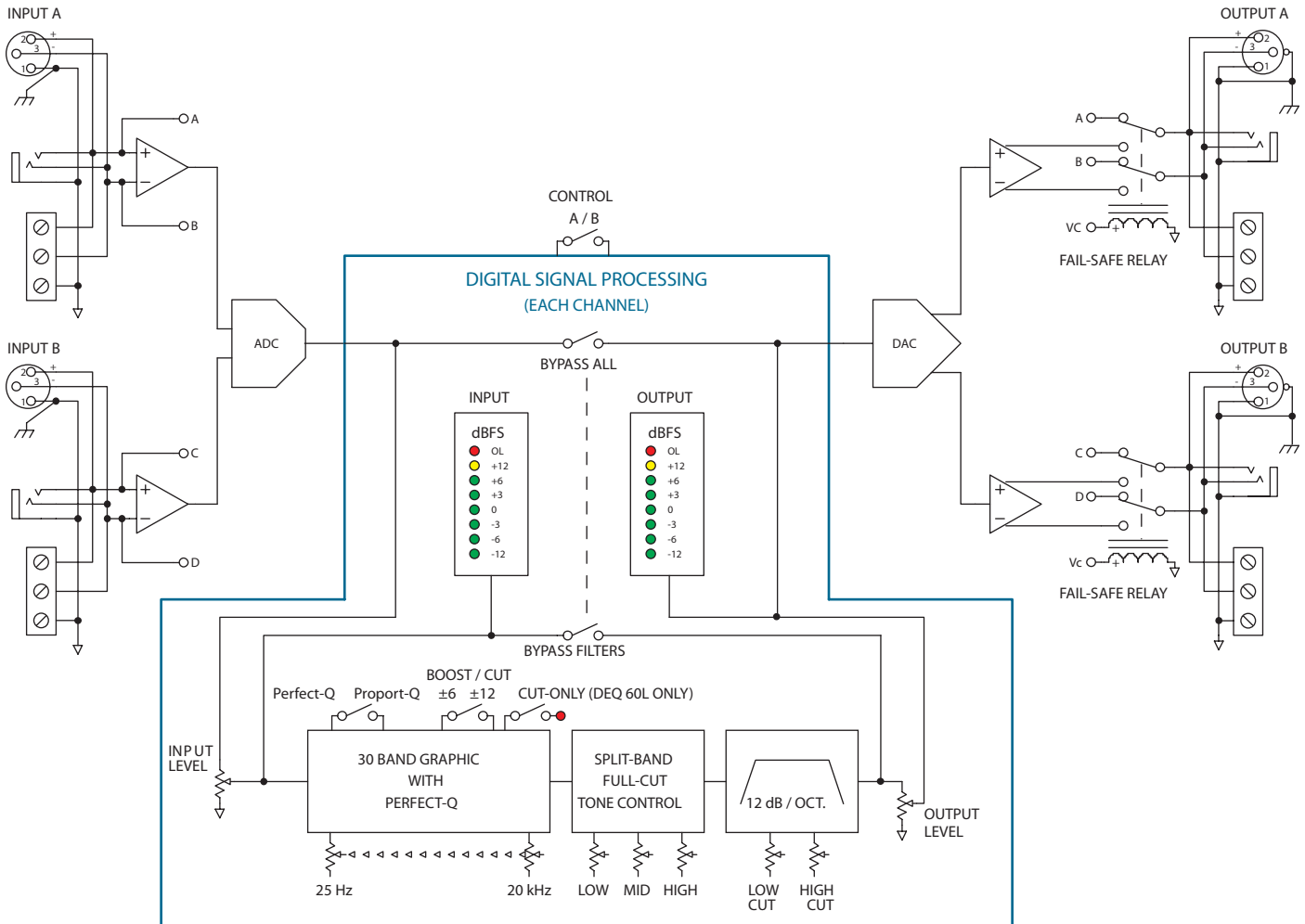

Architectural Specifications

The equalizer shall be analog-controlled, with all control provided on the front panel using 25 mm sliders. All signal processing shall be accomplished using high accuracy digital signal processing. The equalizer shall be a two channel model, and shall occupy two rack spaces (2U). Each channel shall have thirty (30) frequency bands located on standard ISO center frequencies. Each band shall have a bandwidth of 1/3-octave. A detented and guaranteed 0 dB point shall be provided on 25 mm (DEQ 60) or 45 mm (DEQ 60L) linear sliders with dust dams. The equalizer shall be front-panel switchable between two modes, Proportional-Q or Perfect-Q. (*DEQ 60L only: The equalizer shall have a front panel switch selecting cut-only or boost/cut operation.)

Low and high cut filters shall be provided with 12 dB/octave slopes and adjustable corner frequencies. Tone controls shall be provided for Low, Mid and High frequencies. The tone controls shall have a range of +6 dB to off.

Input and Output Level controls shall be provided for each channel. Input and Output peak dBu meters shall be provided. The unit shall provide an automatic passive bypass feature when power is not available, and active bypass switches for each channel when the unit is operating.

The inputs and outputs shall be active balanced/unbalanced designs terminated with XLR, 1/4" TRS (tip-ring-sleeve), and Euroblock terminals. The outputs shall have equal output impedances. RFI filters shall be provided.

The unit shall meet CE and UL agency safety requirements and be powered from an internal universal power supply (100 to 240 VAC) via a rear panel IEC connector. The unit enclosure shall be constructed entirely from cold-rolled steel. The unit shall be supplied with ears for mounting into a standard 2U EIA rack (DEQ 60) or 3U EIA rack (DEQ 60L).

The unit shall be a Rane DEQ 60 or DEQ 60L Graphic Equalizer.

DEQ 60 & DEQ 60L

GRAPHIC EQUALIZERS



DEQ 60 Rear Panel (DEQ 60L not shown, same features in 3U rack height)

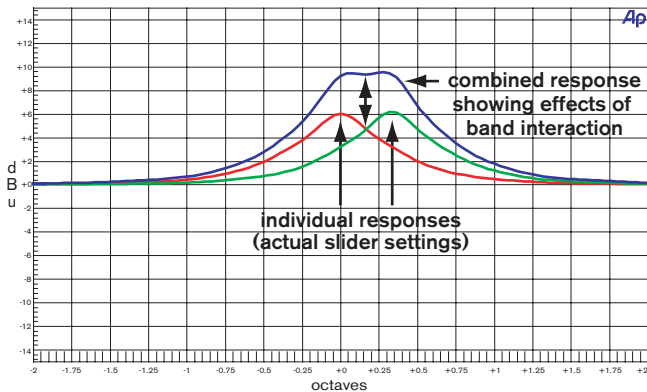
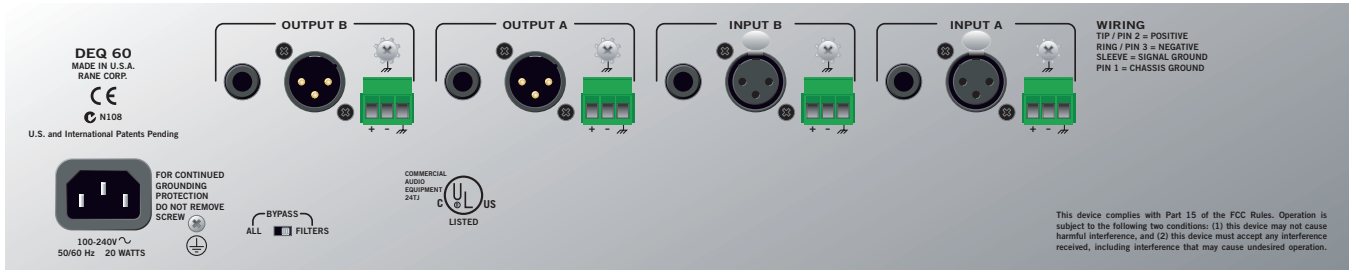

Figure 1. Band interaction of 1/3-octave Proportional-Q filters

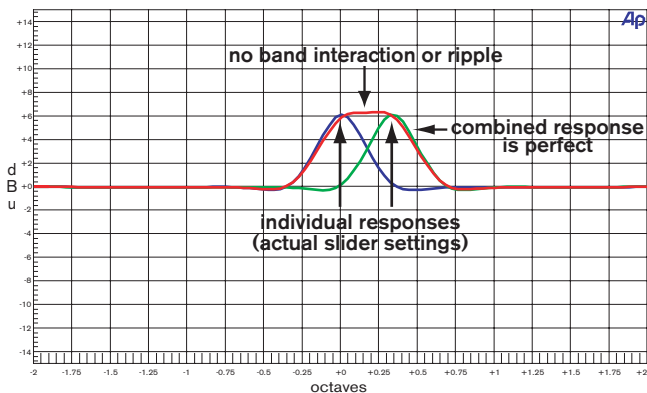

Figure 2. Graphic response of Perfect-Q filters

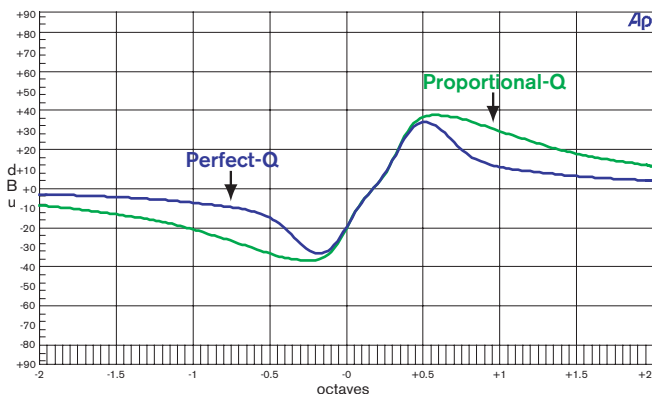

Figure 3. Phase response of Figures 1 and 2.

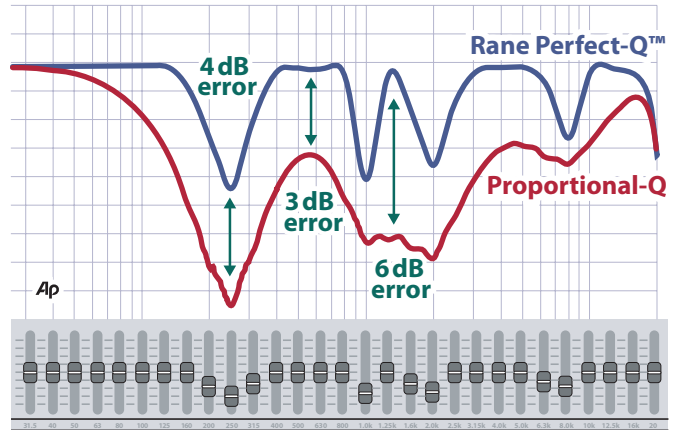

Figure 4. Typical PA adjustment showing the difference between Perfect-Q and Proportional-Q. Which curve more precisely matches the slider positions?

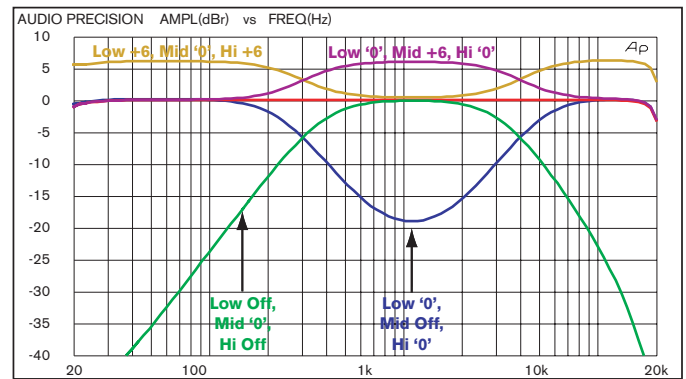

Figure 5. The interactive operation of the 3 Tone controls

References

1. R. Miller, R. Jeffs, S. Radford, D. Bohn, "Perfect-Q, the Next Step in Graphic EQ Design," *RaneNote*, (2003).

Accessories

- The DEQ 60 includes a SC 3.5 Security Cover
- The SC 5.2 Security Cover is optional for the DEQ 60L