

REVISIONS			
REV.	DESCRIPTION	DATE	APPROVED
A	REDRAWN IN SW	7/27/2006	

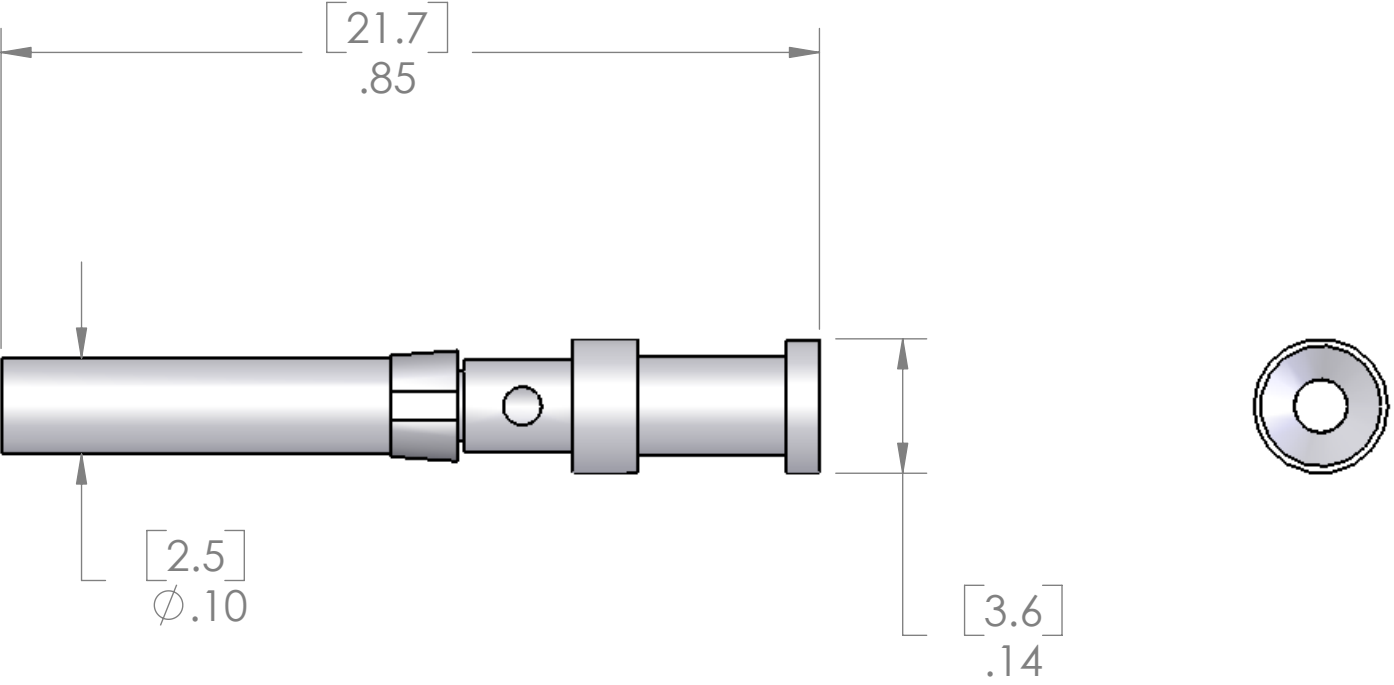

SUGGESTED WIRE STRIP: 0.31 [8]

PART NUMBER	WIRE AWG	SQ. MM
CDFA-0.3	22 - 26	0.3
CDFA-0.5	20	0.5
CDFA-0.7	18	0.75
CDFA-1.0	18	1
CDFA-1.5	16	1.5
CDFA-2.5	14	2.5

MATERIALS	
BODY:	SILVER PLATED COPPER ALLOY
CLIP:	STAINLESS STEEL

PROPRIETARY AND CONFIDENTIAL
 THE INFORMATION CONTAINED IN THIS DRAWING IS THE SOLE PROPERTY OF MENCOM CORPORATION. ANY REPRODUCTION IN PART OR AS A WHOLE WITHOUT THE WRITTEN PERMISSION OF MENCOM CORPORATION IS PROHIBITED.

UNLESS OTHERWISE SPECIFIED:
 DIMENSIONS ARE IN INCHES AND [MM]
 MATERIAL
 FINISH
 DO NOT SCALE DRAWING

NAME	DWM
DRAWN	
CHECKED	
ENG APPR.	
MFG APPR.	
Q.A.	
COMMENTS:	

MENCOM CORPORATION
 TITLE:
 SIZE DWG. NO. REV
B CDFA-X.X **A**
 SCALE: 5:1 WEIGHT: SHEET 1 OF 1