

**NOTES:**

1. SYMBOL  INDICATES CENTER OF BALANCE.
2. WEIGHT APPROX. 74 LBS.
3. SHIPPING WEIGHT APPROX. 82 LBS.

REV	DESCRIPTION	APVD/DATE
C	RELEASED TO PRODUCTION FROM PILOT REV B. PER DSR #01-1163 DM 1/25/02.	RS 2/5/02

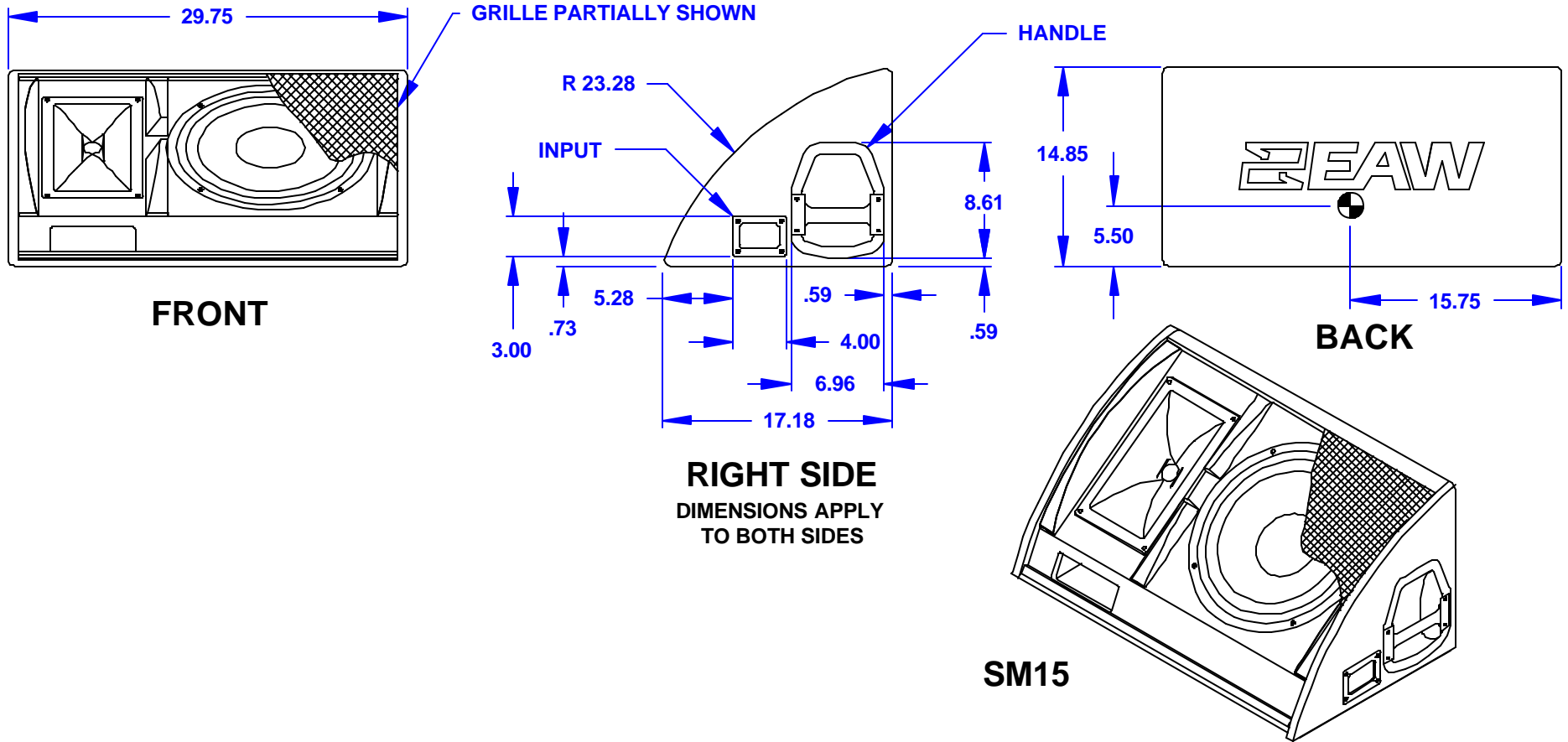

DOCUMENT CONTROL PER SPECIFICATION 4.5.201

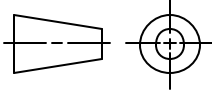
<p>THIRD ANGLE PROJECTION</p> 	<p>UNLESS OTHERWISE SPECIFIED: ALL DIMENSIONS ARE IN INCHES</p> <p>TOLERANCE IN INCHES .XX ± .13 ANGLES ±1°</p> <p>(X.XX) = REF DIMS NO TOLERANCE IMPLIED</p> <p>T.S.C. = THEORETICAL SHARP CORNER</p> <p>DIMENSIONS ACROSS CENTERLINES TO BE SYMMETRICAL</p>	<p>STATUS: <b>PRODUCTION</b></p>		<p><b>EAW</b> EASTERN ACOUSTIC WORKS ONE MAIN STREET WHITINSVILLE, MA 01588 USA</p>
		<p>APPROVALS</p> <p>DRAWN: DM</p> <p>CHECKED: RS</p> <p>DES ENG: JAR</p> <p>MFG ENG: DBD</p>	<p>DATE</p> <p>8/22/00</p> <p>2/5/02</p> <p>2/22/02</p> <p>2/25/02</p>	
<p>THIS DRAWING IS THE PROPERTY OF EAW AND SHALL NOT BE COPIED, REPRODUCED, OR USED AS THE BASIS FOR MANUFACTURE OR SALE OF APPARATUS WITHOUT WRITTEN AUTHORIZATION. DO NOT SCALE DRAWING.</p>		<p>A SHEET 1 OF 1 SCALE: 1 TO 12</p>		<p>DRAWING NUMBER: 509070</p> <p>REVISION: C</p>