

# ILA System v2

## User Manual



**WL2082-i** – Full-range line array loudspeaker

**WL118-sw** – Subwoofer line array loudspeaker

**FB2082-i** – Array frame

**EB2082-i** – Extension bar

**PB2082-i** – Pull-back bar

**GS115-sw** – Ground stack kit

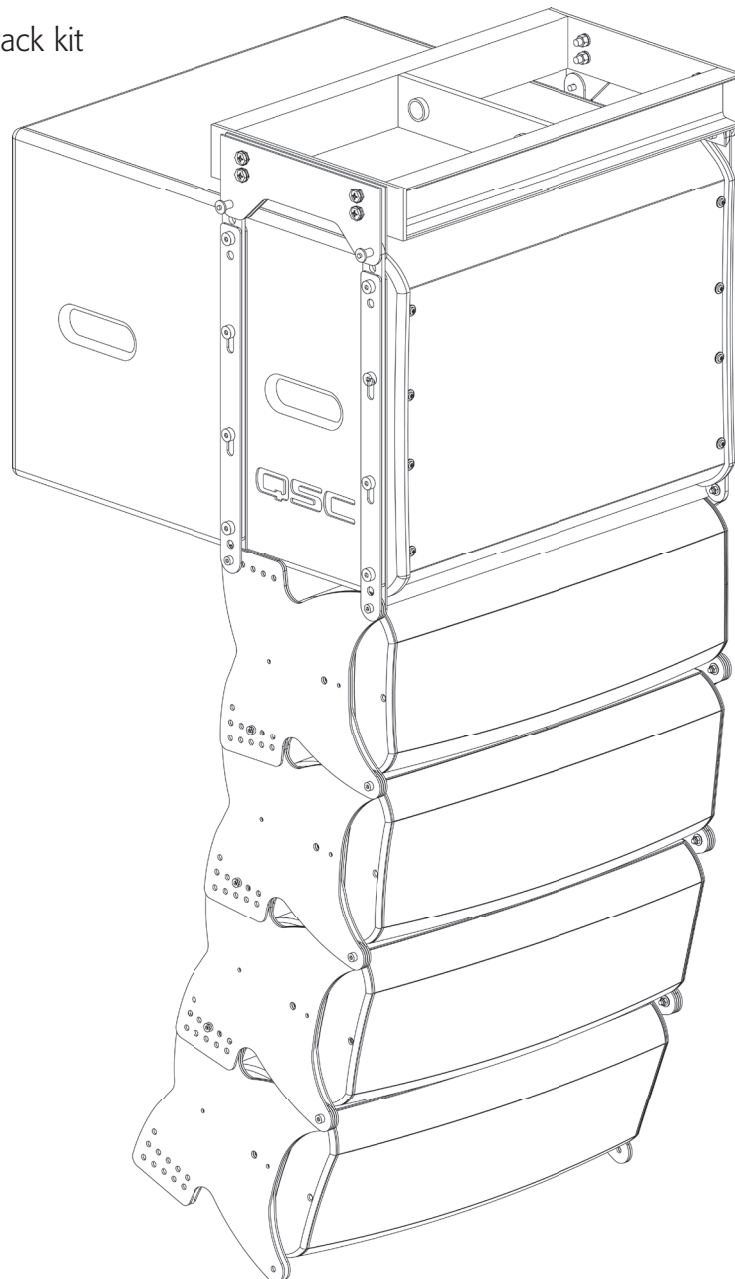

TD-000218-00-E



# IMPORTANT SAFETY PRECAUTIONS AND EXPLANATION OF SYMBOLS

Install in accordance with instructions by QSC Audio Products, LLC instructions and under the supervision of a licensed Professional Engineer.



Before placing, installing, rigging, or suspending any speaker product, inspect all hardware, suspension, cabinets, transducers, brackets and associated equipment for damage. Any missing, corroded, deformed, or non-load rated component could significantly reduce the strength of the installation, placement or array. Any such condition severely reduces the safety of the installation and should be immediately corrected. Use only hardware which is rated for the loading conditions of the installation and any possible short-term, unexpected overloading. Never exceed the rating of the hardware or equipment.

Consult a licensed, Professional Engineer regarding physical equipment installation. Ensure that all local, state and national regulations regarding the safety and operation of suspended equipment are understood and adhered to.

## Warranty (USA only; other countries, see your dealer or distributor)

### Disclaimer

QSC Audio Products, LLC is not liable for any damage to amplifiers or any other equipment that is caused by negligence or improper installation and/or use of this loudspeaker product.

### QSC Audio Products 3-Year Limited Warranty

QSC Audio Products, LLC ("QSC") guarantees its products to be free from defective material and/or workmanship and will replace defective parts and repair malfunctioning products under this warranty when the defect occurs under normal installation and use-provided the unit is returned to our factory, one of our authorized service stations or an authorized QSC International Distributor via pre-paid transportation with a copy of proof of purchase (i.e., sales receipt). This warranty provides that the examination of the return product must indicate, in our judgment, a manufacturing defect. This warranty does not extend to any product which has been subjected to misuse, neglect, accident, improper installation, or where the date code has been removed or defaced. QSC shall not be liable for incidental and/or consequential damages. This warranty gives you specific legal rights. This limited warranty is freely transferable during the term of the warranty period. The warranty on QSC products is NOT VALID if the products have been purchased from an unauthorized dealer/online e-tailer, or if the original factory serial number has been removed, defaced, or replaced in any way. Damage to, or loss of any software or data residing on the product is not covered. When providing repair or replacement service, QSC will use reasonable efforts to reinstall the product's original software configuration and subsequent update releases, but will not provide any recovery or transfer of software or data contained on the serviced unit not originally included in the product.

Customers may have additional rights, which vary from state to state or from country to country. In the event that a provision of this limited warranty is void, prohibited or superseded by local laws, the remaining provisions shall remain in effect.

Periodically, this warranty is updated. To obtain the most recent version of QSC's warranty statement, please visit [www.qscaudio.com](http://www.qscaudio.com).

Contact us at 800-854-4079 or visit our website at [www.qscaudio.com](http://www.qscaudio.com).

**The QSC limited warranty is valid for a period of three (3) years from date of purchase in the United States and many (but not all) other countries.**

For QSC warranty information in countries other than the United States, contact your authorized QSC international distributor. A list of QSC International distributors is available at [www.qscaudio.com](http://www.qscaudio.com).

To register your QSC product online, go to [www.qscaudio.com](http://www.qscaudio.com) and select "Product Registration". Other questions regarding this warranty can be answered by calling, e-mailing or contacting your authorized QSC distributor.

© 2009, QSC Audio Products, LLC.

Patents may apply or be pending.

QSC is a registered trademark of QSC Audio Products, LLC.

"QSC" and the QSC logo are registered with the U.S. Patent and Trademark Office.

All trademarks are the property of their respective owners.

# Introduction

The Installation Line Array (ILA) is a high performance line array system designed for the needs of Houses of Worship, Performing Arts facilities and a multitude of other venue types. The current ILA family is composed of the WL2082-i line array element, WL118-sw subwoofer, FB2082-i array frame, PB2082-i pull-back bar, EB2082-i extension bar, and GS115-sw ground stack kit.

Installation Line Arrays may be used in outdoor applications where the system is somewhat protected from the elements. The enclosure material is formulated with UV inhibitors, the grille is made of aluminum and the woofer cones are weather resistant.

## WL2082-i

The WL2082-i line array element uses two high-power, neodymium magnet, 2" voice-coil, 8" low-frequency drivers in a two-and-a-half-way configuration. Both woofers produce low frequencies but only one covers the mid-range, resulting in far better horizontal directivity control in the crossover region. Excellent high-frequency output and clarity are provided by a pair of 1.75" voice coil, neodymium magnet compression drivers with titanium diaphragms. These drivers are mounted to QSC's patented\* multiple-aperture diffraction waveguide that provides an extremely wide horizontal coverage of 140°. As a result, systems will rarely require side or center fill speakers and solid stereo imaging is preserved across the listening area.

The low-frequency capability of a WL2082-i array extends to 68 Hz (-10 dB); adequate for speech/vocal and acoustic music program material. For reinforcement of program material with more demanding low-frequency content, the WL118-sw companion subwoofer is available.

### WL2082-i Loudspeaker

1. Rigging plate attachment holes
2. Grille
3. Splay angle selection holes (rear of rigging plates)
4. Grille retaining screws (one on each end of enclosure)
5. Rigging plate retaining bolt
6. Rigging alignment notch
7. Rigging plates
8. Input plate
9. Rigging alignment pin
10. Horizontal Shading selector switch
11. BI AMP/TRI AMP Mode selector switch
12. Wiring table
13. NL8 Speakon™ connectors

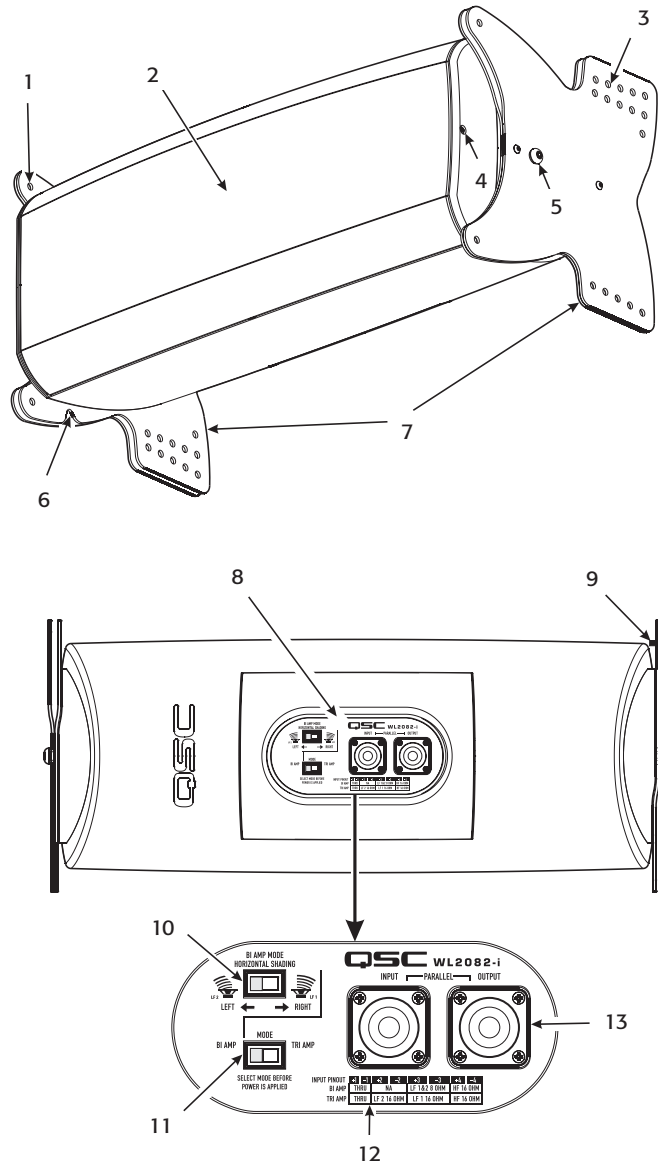

\*Patent number 7,177,437

## Introduction (continued)

### WL118-sw

The WL118-sw subwoofer extends the system's low-frequency capability to 35 Hz. Its ceramic magnet, 4" voice coil, 18" transducer provides 850 watt continuous power handling capability.

Many users of line array systems have found that suspending the subwoofers with the array provides audible benefit. Additionally, many venues lack physical space for floor-mounted subs. For these reasons, the WL118-sw includes rigging hardware and, with selection of the appropriate rigging accessories, subwoofers may be flown at the top of or behind a WL2082-i array.

### WL118-sw Subwoofer

1. Rigging straps
2. Grille
3. Handles
4. Rigging strap retaining bolts
5. Input panel
6. NL8 and NL4 Speakon™ connectors

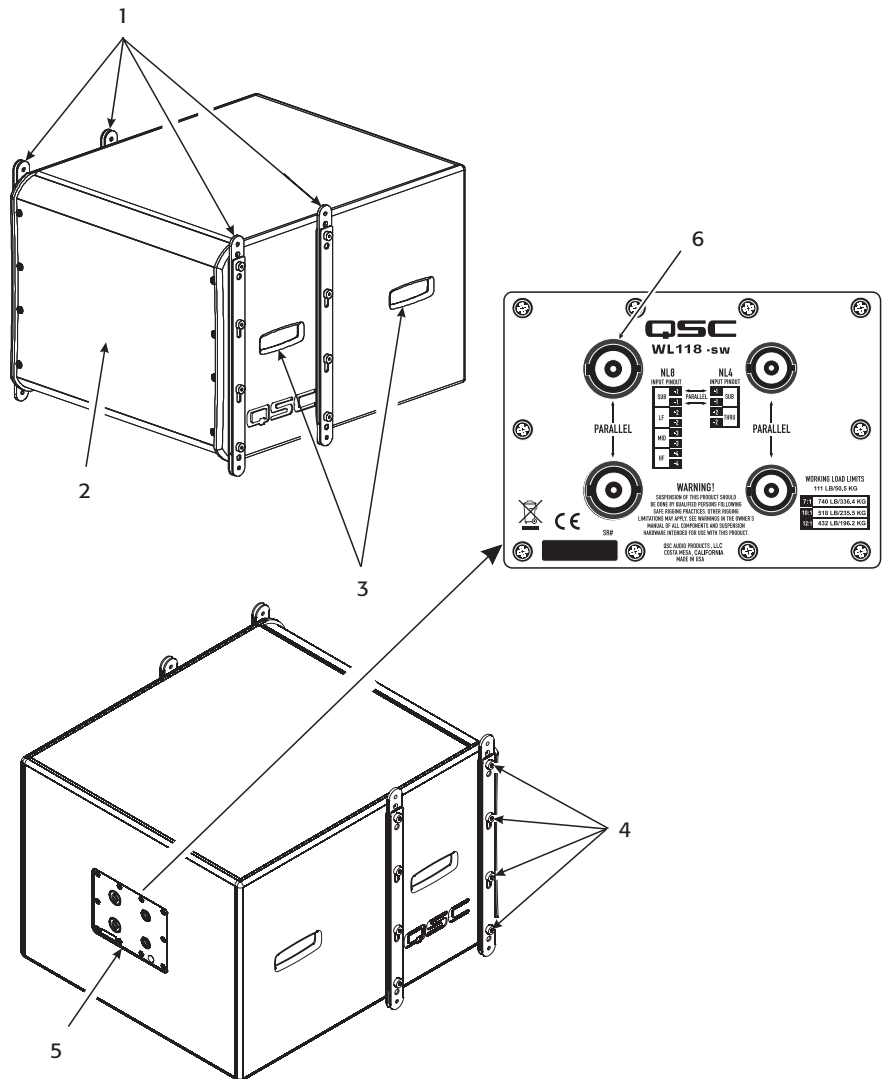

## Rigging

Rigging the Installation Line Array is simple and flexible. Enclosures are bolted together with the provided M8 shoulder bolts or pinned together with optional quick-release ball-lock pins.

The FB2082-i array frame supports most flown array applications, and the EB2082-i extension bar supports suspension where the center of gravity is beyond the limits of the FB2082-i. Additionally, the EB2082-i is used for arrays where subwoofers are flown behind the main array. The PB2082-i pull-back bar is used for pulling back the bottom element of the array for aiming and stability or as the primary suspension component for certain small arrays.

Ground stacking is easily accomplished using the GS115-sw ground stack kit. The kit includes two ground stack rails which attach to the rigging straps under the WL118-sw. These rails provide added stability and allow for ground stacked arrays to be constructed.

## Introduction (continued)

### FB2082-i Array Frame

1. Shackle holes (accept 3/4" (20 mm) screw pin anchor shackle)
2. Center support bar
3. Rigging plates
4. Rigging plate retaining bolts
5. Rigging plate attachment holes

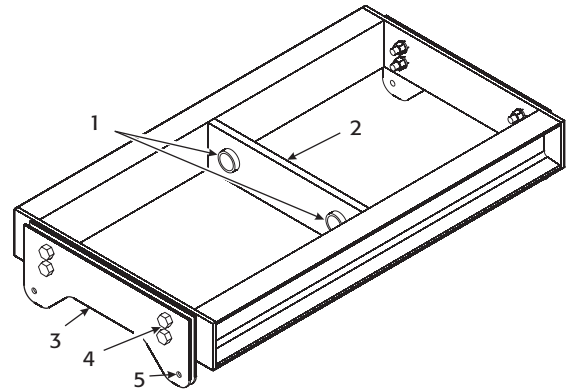

**WARNING!** Use only shackle holes for suspension of array!

### PB2082-i Pull-Back Bar

1. Shackle hole (accepts 5/8" (16 mm) screw pin anchor shackle)
2. Rigging plate attachment holes
3. Rigging plates
4. Rigging plate retaining bolts

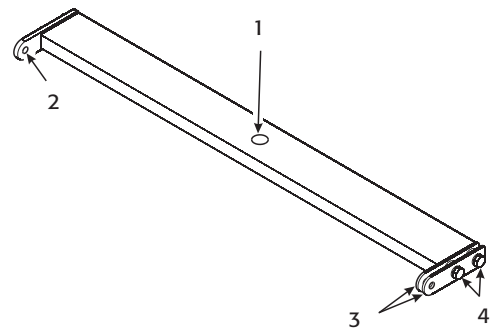

**WARNING!** Use only shackle hole for suspension of array!

### EB2082-i Extension Bar

1. Extension bar
2. Rigging plate retaining bolts
3. Shackle holes (accept 3/4" (20 mm) screw pin anchor shackle)
4. Rigging plates

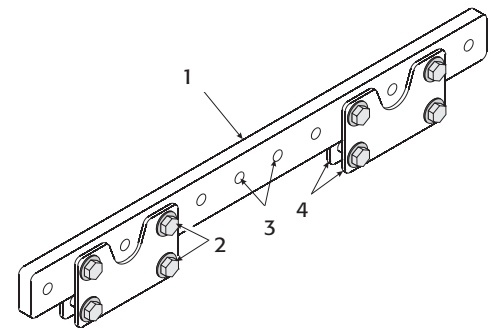

**WARNING!** Use only shackle hole for suspension of array!

### GS115-sw Ground Stack Kit

1. Rail
2. Rubber foot
3. Attachment holes

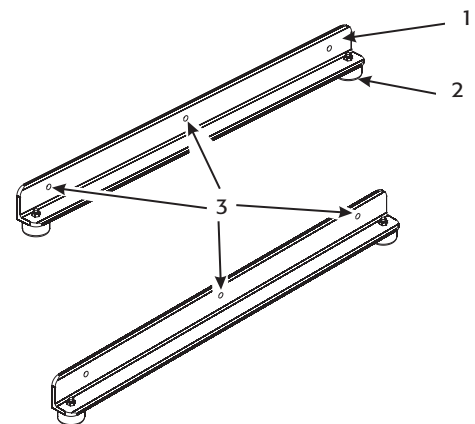

# Rigging the Installation Line Array

## Rules for Suspension

- Correct use of all suspension hardware and components is imperative in sound system rigging and deployment.
- Always calculate suspended loads before lifting to ensure suspension components and hardware are used within their respective load limits.
- Research local codes and regulations to fully understand the requirements for suspended loads in the venue in which the equipment is to be suspended.
- Use only shackle holes for suspension of array.
- Be absolutely certain of the integrity of any structural member intended to support suspended loads. Hidden structural members can have hidden structural weakness.
- Consult a Professional Mechanical or Structural Engineer licensed in the jurisdiction of the sound system installation to review, verify, and approve all attachments to the building or structure.
- Never assume anything—owner or third-party supplied suspension attachment points may not be adequate for the loads to be suspended.
- Employ the services of a Professional Rigger for hoisting, positioning, and attaching the equipment to the supporting structure.
- Always inspect all components (enclosures, suspension brackets, pins, frames, bolts, nuts, slings, shackles, etc.) for cracks, wear, deformation, corrosion, missing, loose, or damaged parts that could reduce the strength of the assembly before lifting. Discard any worn, defective, or suspect parts and replace them with new appropriately load-rated parts.

## Shock Loading

When a load is either moved or stopped, its static weight is magnified. Sudden movements can magnify the static weight several times. This magnification of static weight is termed “shock loading.” Shock loading poses a danger to equipment and workers. The effects of shock loading can be instantaneous, or they may remain undetected unless the equipment is visually damaged. Avoiding shock loading requires careful planning and knowledge of equipment, rigging, and lifting practices.

Shock loading of equipment and structures is usually confined to lifting and installation, but natural forces (winds, earthquakes) can impose shock loads several times the static load. This is why structures and suspension equipment must be capable of supporting several times the weight of the equipment suspended.

## ILA Working Load Limits and Design Factors

The following table lists ILA suspension components and provides Working Load Limit data at various Design Factors. The tabulated Design Factors are for static loads only. The choice of which Design Factor to use will depend upon the jurisdiction and venue of installation, as well as the conditions of suspension. Dynamic conditions are determined by unknown, installation-specific factors and should be referred to a Licensed Structural Engineer for clarification before proceeding with any suspension of the equipment. The data presented is based upon the listed component weights:

**Table 1: ILA Working Load Limits**

Component	Weight	7:1 Design Factor	10:1 Design Factor	12:1 Design Factor
EB2082-i Extension Bar	38 lb (17.3 kg)	1714 lb (779.2 kg)	1200 lb (545.5 kg)	1000 lb (454.5 kg)
FB2082-i Array Frame	17 lb (7.7 kg)	740 lb (336.4 kg)	518 lb (235.5 kg)	432 lb (196.2 kg)
PB2082-i Pull-Back Bar	6 lb (2.7 kg)	423 lb (192.2 kg)	296 lb (134.5 kg)	247 lb (112.1 kg)
WL2082-i Loudspeaker	37 lb (16.8 kg)	634 lb (288.3 kg)	296 lb (134.5 kg)	371 lb (168.6 kg)
WL118-sw Loudspeaker	111 lb (50.5 kg)	740 lb (336.4 kg)	518 lb (235.5 kg)	432 lb (196.2 kg)
M8 Shoulder Bolt <sup>1</sup>	N/A	1003 lb (455.8 kg)	702 lb (319.1 kg)	585 lb (265.9 kg)
M8 Ball-lock Pin <sup>1</sup>	N/A	1810 lb (822.7 kg)	1267 lb (575.9 kg)	1056 lb (479.9 kg)
M8 Locking Plate <sup>1</sup>	N/A	1286 lb (584.4 kg)	900 lb (409.1 kg)	750 lb (340.9 kg)
M12 Shoulder Bolt <sup>1</sup>	N/A	4744 lb (2156.3 kg)	3321 lb (1509.4 kg)	2767 lb (1257.8 kg)
3/8" Fastener <sup>1</sup>	N/A	1943 lb (883.4 kg)	1360 lb (618.4 kg)	1134 lb (515.3 kg)
7/8" Fastener <sup>1</sup>	N/A	8110 lb (3686.4 kg)	5677 lb (2580.5 kg)	4731 lb (2150.4 kg)

<sup>1</sup>- Working Load Limits are per fastener loaded in double shear. Data is for informational purposes only.

## Attaching WL2082-i to Array Frame (Figure 1)

Before beginning any installation, have your system designer calculate the proper splay angles using QSC's EASE Focus (Array Calculator). All orientation of product is to be as viewed from the rear of the enclosure.

Attach the array frame to the suspension structure using a 3/4" (20 mm) screw pin anchor shackle and appropriate sling, cable, etc.

For arrays of four WL2082-i or less, assemble the cluster of WL2082-i on the ground using the included mating hardware. Ensure the notched rigging plate is on the right hand side (the system can only be installed one way. Note the QSC logo on the input plate will be right side up when the enclosure is oriented properly). During assembly, ensure your splay angles are as desired.

When constructing large arrays it is recommended to first assemble units of four enclosures and then assemble the final array by joining the four enclosure units to one another.

Attachment of one enclosure to another is accomplished by inserting the cap-head shoulder bolt with washer through the rigging plate attachment holes and appropriate splay angle selection holes in the mating rigging plates and threading the lock nut (nylock) on the inside edge of the plates. The bolt should be tightened snugly to no more than 5 lb-ft of torque (6.8 N-m).

Attach the array frame to the top enclosure by inserting the cap-head shoulder bolt with washer through the appropriate mounting holes and threading the lock nut (nylock) on the inside edge of the plates. The bolt should be tightened snugly to no more than 5 lb-ft (6.8 N-m) of torque.

**NOTE:** For some array configurations, use of the extension bar and/or pull-back may be required to achieve the required aiming angle.

## Pull-Back Bar (Figure 2)

If using the pull-back bar, attach to the bottom enclosure at the bottom-most splay angle adjustment holes at the rear of the rigging plate by inserting the cap-head shoulder bolt through the mated pieces and threading the lock nut (nylock) on the inside edge of the plates. Use a 5/8" (16 mm) shackle to attach to the pull-back bar shackle hole located in the center of the main bar.

**NOTE:** All hardware/components must be rated for the expected loads as determined by the Professional Engineer responsible for suspension.

**NOTE:** A washer should not be used when attaching the pull-back bar. This will allow the pull-back bar to pivot freely.

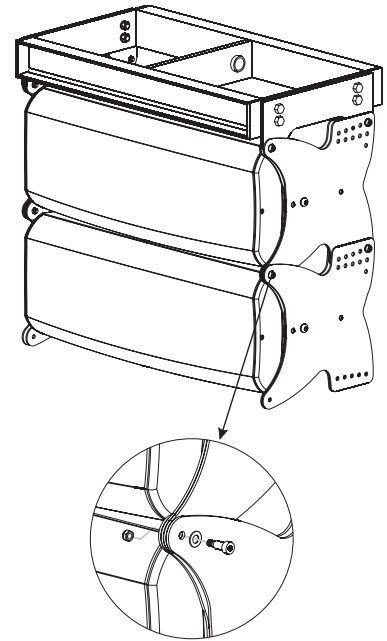

– Figure 1 –

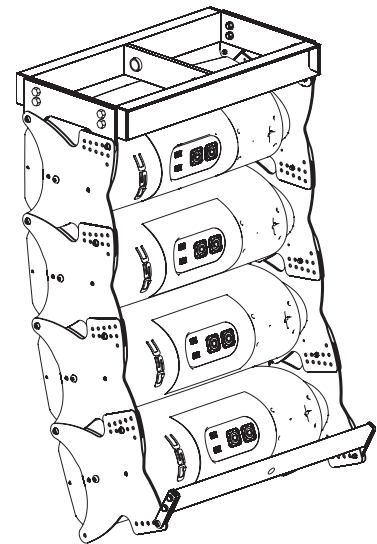

– Figure 2 –

## Rigging the Installation Line Array (continued)

### Extension Bar (Figure 3)

The extension bar rigging plates can be moved, if required, by removing the two 7/8" mounting bolts, moving to the selected mounting location, and reattaching. Tightening torque is to be 100 lb-ft of torque (135.6 N-m) EASE Focus software's center-of-gravity calculator will provide a suitable point (or two points) for desired down-tilt. Attach the array frame to the extension bar rigging plates by centering the array frame member between the extension bar rigging plates and bolting together using the supplied 7/8" bolts.

### Attaching the WL118-sw to the Array Frame (Figure 4)

All orientation of product is to be as viewed from the rear of the enclosure. The QSC logo on the input plate will appear right side up when the enclosure is oriented properly.

Attach the array frame to the suspension structure using 3/4" (20 mm) shackle and appropriate sling, cable, etc.

For all four rigging straps: Using a 6 mm hex wrench, remove the upper and lower rigging strap retaining bolts and loosen the two bolts in between. Pull the inner and outer straps to their outermost position; pull the center strap to its outermost position, and align the retaining bolt holes with the threaded inserts of the enclosure. Re-install the outermost rigging strap retaining bolts and tighten all four bolts on each strap to 13 lb-ft (17.6 N-m).

Lower the array frame onto the enclosure, carefully aligning the rigging straps, and attach the top enclosure to the array frame by installing the ball-lock pins or M8 bolts. Before lifting, ensure the audio connection to the enclosures are correct and functioning (Figure 5).

 **NOTE:** When attaching one WL118-sw to another WL118-sw, you must use the supplied ball-lock pins. This will allow for easier installation given the close spacing between consecutive WL118-sw enclosures.

 **NOTE:** When arraying two or more WL118-sw subwoofers, it is easiest to lay the enclosures on their backs, align and mate the rigging straps, and install the ball-lock pins. When installing the ball-lock pins, ensure full insertion and locking action. (Figure 6)

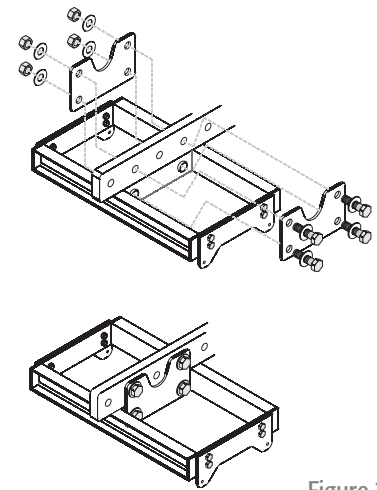

- Figure 3 -

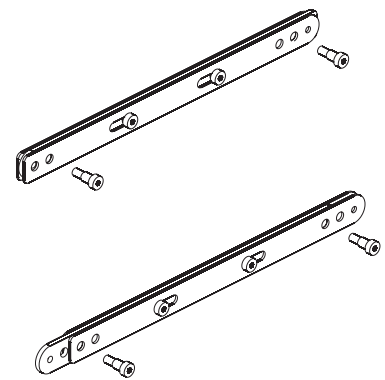

- Figure 4 -

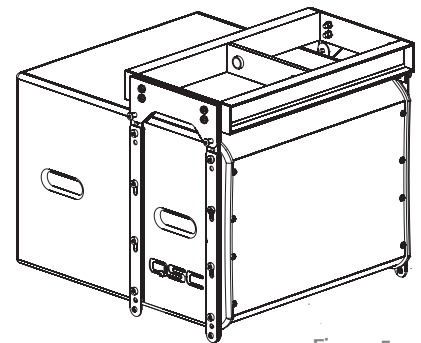

- Figure 5 -

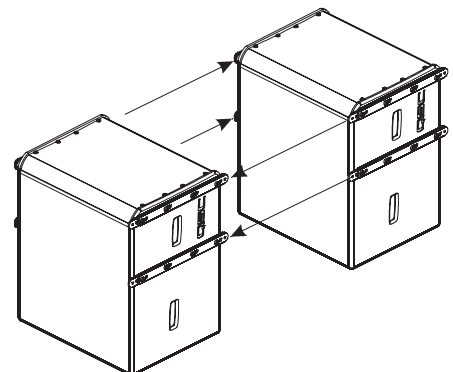

- Figure 6 -



## Rigging the Installation Line Array (continued)

### Attaching the GS115-sw Ground Stack Rails to a WL118-sw (Figure 7)

For all four rigging straps: Using a 6 mm hex wrench, remove the upper and lower rigging strap retaining bolts and loosen the two bolts in between. Pull the inner and outer straps to their outermost position; pull the center strap to its outermost position, and align the retaining bolt holes with the threaded inserts of the enclosure. Re-install the outermost rigging strap retaining bolts and tighten all four bolts on each strap to 13 lb-ft (17.6 N-m).

Position a GS115-sw ground stack rail between the rigging straps on the right and one to the outside of the rigging straps on the left side of the loudspeaker.

Attach the rail to the rigging strap by inserting the cap-head shoulder bolt with washer through the mated components and threading the lock nut (nylock) on the inside edge of the assembly. The bolt should be tightened snugly to no more than 5 lb-ft (6.8 N-m).

 **NOTE:** GS115-sw must be attached to at least one WL118-sw for stability before any additional loudspeakers are attached. GS115-sw should never be attached directly to a WL2082-i loudspeaker.

 **NOTE:** GS115-sw is designed to accommodate up to two WL118-sw loudspeakers and up to six WL2082-i loudspeakers.

### Attaching WL2082-i enclosures beneath WL118-sw enclosures (Figure 8)

For arrays of four WL2082-i loudspeakers or less, assemble the WL2082-i loudspeakers on the ground using the included mating hardware. Ensure the notched rigging plate is on the right hand side (the system can only be installed one way; the QSC logo on the input plate will appear right side up when the enclosure is oriented properly). During assembly, ensure your splay angles are as desired.

When constructing large arrays it is recommended to first assemble units of four enclosures and then assemble the final array by joining the four enclosure units to one another.

Attachment of one enclosure to another is accomplished by inserting the cap-head shoulder bolt with washer through the mated rigging plates and appropriate splay angle selection holes and threading the lock nut (nylock) on the inside edge of the plates. The bolt should be tightened snugly to no more than 5 lb-ft (6.8 N-m).

Lower the array frame with subwoofer(s) onto the WL2082-i enclosure cluster and attach the top enclosure to subwoofer by inserting the cap-head shoulder bolt with washer through the mounting holes and threading the lock nut (nylock) on the inside edge of the plates and rigging straps.

 **NOTE:** See Pull-Back Bar and Extension Bar sections on previous page for information regarding their use.

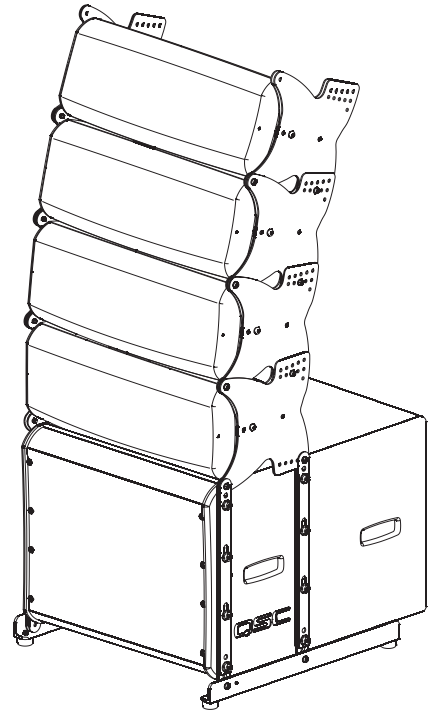

– Figure 7 –

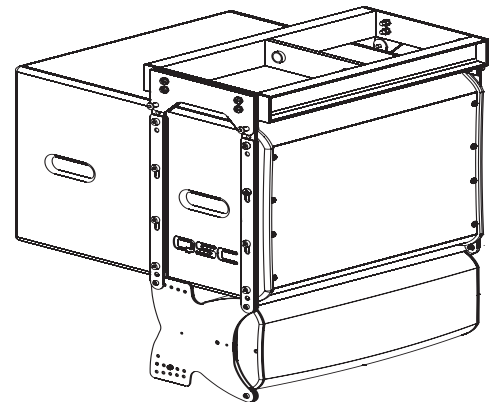

– Figure 8 –

## Rigging the Installation Line Array (continued)

### Attaching WL118-sw Behind WL2082-i Array Using EB2082-i (Figure 9)

It is sometimes necessary to suspend the subwoofers behind the main array. Extreme splay angles may result in physical interference with rear-flown subwoofers.

Attach both array frames to the extension bar rigging plates by centering the array frame member between the extension bar rigging plates and bolting together using the supplied 7/8" bolts. The extension bar rigging plates can be moved, if required, by removing the two 7/8" mounting bolts, moving to the selected mounting location, and reattaching. Tightening torque is to be 100 lb-ft (135.6 N-m). EASE-Focus software's center-of-gravity calculator will provide a suitable point (or two points) for desired down-tilt.

The rear suspended WL118-sw subwoofer(s) may now be attached to the array frame; see "Attaching the WL118-sw to the Array Frame."

The front suspended WL2082-i loudspeakers may now be attached to the array frame; see "Attaching WL2082-i to Array Frame."

 **NOTE:** When stacking loudspeakers for attachment to array frames using the extension bar, we recommend working with groups of 2 WL2082-i for each WL118-sw. Start with no splay angle; this yields the same height for landing the extension bar. Adjust splay angle once the rig is lifted.

### Suspending Four or Less WL2082-i Loudspeakers Using Two Pull-Back Bars (Figure 10)

 **NOTE:** Do not suspend more than four WL2082-i loudspeakers from a PB2082-i pull-back bar! Do not use PB2082-i pull-back bar for suspending anything other than 4 or less WL2082-i loudspeakers! Do not suspend the WL118-sw from the PB2082-i pull-back bar!

 **NOTE:** A washer should not be used when attaching the pull-back bar. This will allow the pull-back bar to pivot freely.

 **Warning!** Four (4) WL2082-i loudspeakers is the maximum allowable load (10:1 design factor) for the PB2082-i. Do not suspend more than four WL2082-i loudspeakers from the PB2082-i.

Assemble the array of WL2082-i loudspeakers on the ground using the included mating hardware. Ensure the notched rigging plate is on the right hand side (the system can only be installed one way). Note the QSC logo on the input plate will appear right side up when the enclosure is oriented properly.

Attachment of one enclosure to another is accomplished by inserting the cap-head shoulder bolt with washer through the mated rigging plates and appropriate splay angle selection holes and threading the lock nut (nylock) on the inside edge of the plates. The bolt should be tightened snugly to no more than 5 lb-ft of torque (6.8 N-m).

Attach one PB2082-i to the top enclosure's front, top rigging plate attachment holes by inserting the cap-head shoulder bolts **without** washers through the mated pieces and threading the lock nut (nylock) on the inside edge of the plates. The bolts should be tightened snugly to no more than 5 lb-ft of torque. See (Figure 1) for assembly detail. Use a 5/8" (16 mm) screw pin anchor shackle to attach to the pull-back bar shackle hole located in the center of the pull-back bar for lifting.

Attach the second PB2082-i to the bottom enclosure at the bottom-most splay angle adjustment holes at the rear of the rigging plate by inserting the cap-head shoulder bolts **without** washers through the mated pieces and threading the lock nut (nylock) on the inside edge of the plates. The bolts should be tightened snugly to no more than 5 lb-ft (6.8 N-m) of torque. Use a 5/8" (16 mm) screw pin anchor shackle to attach to the pull-back bar shackle hole located in the center of the main bar for pulling back.

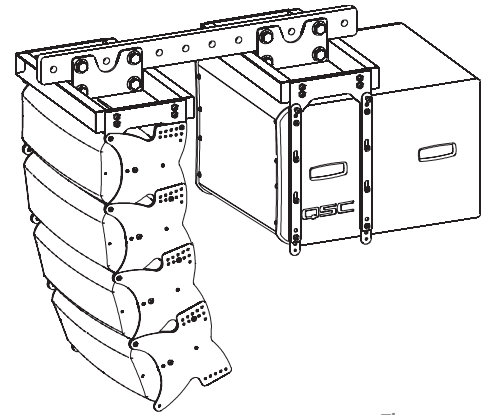

– Figure 9 –

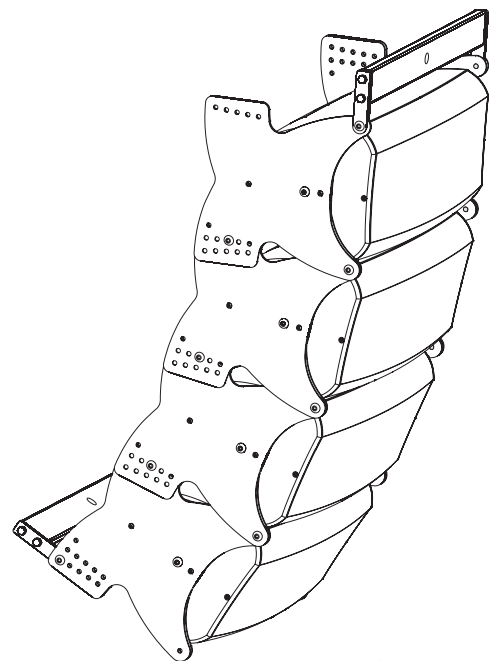

– Figure 10 –

# WL2082-i Controls and Connections

## MODE Selection Switch (Figure 11)

**BI AMP:** When set to BI AMP, an internal shading network removes the mid frequencies from one of the low-frequency drivers. The BI AMP HORIZONTAL SHADING switch will select which transducer is shaded.

**TRI AMP:** Shading network is NOT applied (shading must be provided by upstream signal processing). The BI AMP HORIZONTAL SHADING selector switch is not functional in tri-amp mode. Connect to the Speakon as shown for tri-amp (Table 2).

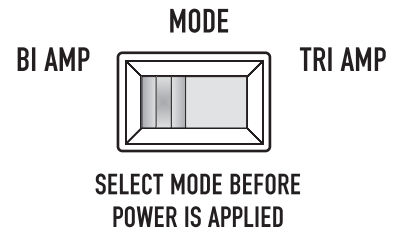

– Figure 11 –

## BI AMP MODE HORIZONTAL SHADING

### Selection Switch (Figure 12)

The BI AMP MODE HORIZONTAL SHADING selection switch is only functional in bi-amp mode. This switch determines which low-frequency transducer receives only low-frequency program material (shading). The unshaded transducer receives low- and mid-frequency program material. This allows switch position selection for use as either “house left” or “house right,” without the need to flip boxes.

**NOTE:** LEFT and RIGHT markings on the BI AMP HORIZONTAL SHADING SWITCH apply to the enclosure as viewed from the rear (i.e. looking at the Input Plate with the text properly oriented).

**LEFT:** Use this setting to shade out mid frequencies in the left (as viewed from behind the arrays, looking toward the audience).

**RIGHT:** Use this setting to shade out mid frequencies in the right (as viewed from behind the arrays, looking toward the audience).

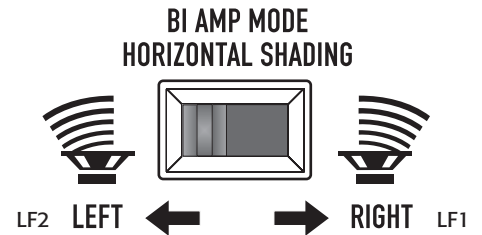

– Figure 12 –

**Table 2: WL2082-i Connector Pinout for BI AMP and TRI AMP Mode**

PIN	BI AMP	TRI AMP
1+	Thru	Thru
1-	Thru	Thru
2+	N/A	Left Low-frequency Transducer + (16 Ohms)
2-	N/A	Left Low-frequency Transducer - (16 Ohms)
3+	Left and Right Low-frequency Transducers in Parallel + (8 Ohms)	Right Low-frequency Transducer + (16 Ohms)
3-	Left and Right Low-frequency Transducers in Parallel - (8 Ohms)	Right Low-frequency Transducer - (16 Ohms)
4+	High-frequency Transducer + (16 Ohms)	High-frequency Transducer + (16 Ohms)
4-	High-frequency Transducer - (16 Ohms)	High-frequency Transducer - (16 Ohms)

## Input Connections (Figure 13)

The WL2082-i input connectors are a pair of Neutrik NL8’s wired in parallel. Connections for bi-amp and tri-amp vary (Table 2).

**NOTE:** The WL2082-i loudspeaker is not equipped with a crossover network. All signal processing must be done before connecting audio power to the loudspeaker. Do not connect full-range audio to the high-frequency transducer or damage may result!

INPUT PINOUT	+1	-1	+2	-2	+3	-3	+4	-4
BI AMP	THRU		NA		LF 1 & 2 8 OHM		HF 16 OHM	
TRI AMP	THRU		LF 2 16 OHM		LF 1 16 OHM		HF 16 OHM	

– Figure 13 –

# WL118-sw Connections

## Input Connections

The WL118-sw input connectors are a pair of Neutrik NL8s wired in parallel for use in a 4-way system. A pair of Neutrik NL4's in Parallel are added for use as a stand alone subwoofer (Table 2).

**Table 3: WL118-sw Connector Pinout**

NL8 Connectors	
PIN	Band-pass
1+	Subwoofer + (8 Ohms)
1-	Subwoofer - (8 Ohms)
2+	Thru (+LF)
2-	Thru (-LF)
3+	Thru (+MID)
3-	Thru (-MID)
4+	Thru (+HF)
4-	Thru (-HF)

NL4 Connectors	
PIN	Band-pass
1+	Subwoofer + (8 Ohms)
1-	Subwoofer - (8 Ohms)
2+	Thru (+LF)
2-	Thru (-LF)

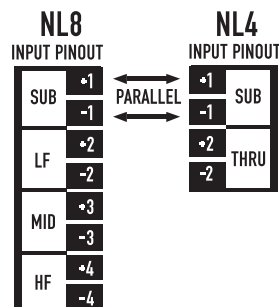
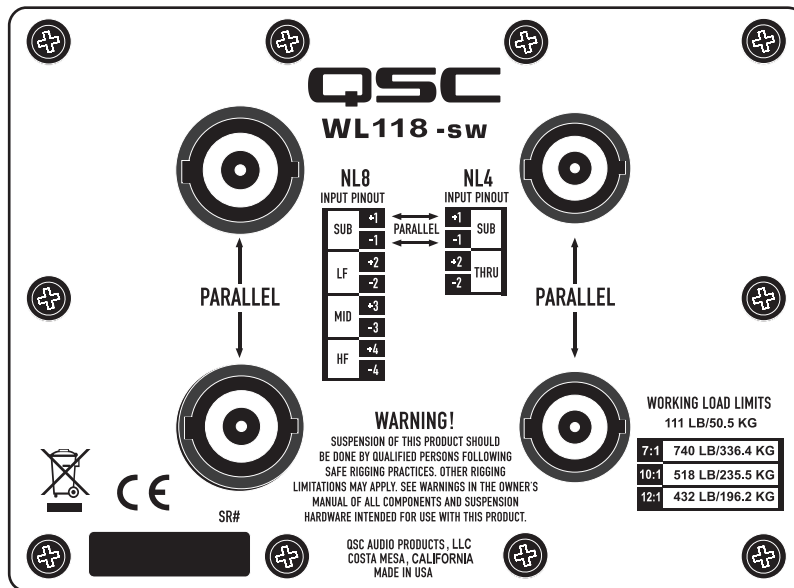

# WL2082-i / WL118-sw Specifications

	WL2082-i	WL118-sw																																			
Configuration	3-way, bi-amp or tri-amp mode	Direct radiating vented box																																			
Transducers																																					
High-frequency	Dual 50 W, 8Ω 1" exit, 1.75" titanium diaphragm, neodymium magnet assembly	–																																			
Low-frequency	Dual 200 W, 16Ω 8" woofer, 2" voice coil, neodymium magnet assembly, weather resistant cone	850 W, 8Ω 18" woofer with a 4" voice coil, ceramic magnet assembly																																			
Frequency Response (±3 dB)	80 Hz – 20 kHz	32 Hz – 200 Hz																																			
Frequency Range (-10 dB)	68 Hz – 22 kHz	29 Hz – 800 Hz																																			
Nominal Impedance	HF: 16Ω LF bi-amp mode: 8Ω LF tri-amp mode: 16Ω (x 2)	– – LF: 8Ω																																			
Continuous Power Capacity/ Recommended Power	HF: 100 W/200 W LF bi-amp mode: 400 W/800 W LF tri-amp mode: 200 W/400 W (x 2)	– – LF: 850 W/1750 W																																			
Sensitivity (1 W at 1 m)	HF: 106 dB LF: 96 dB	– LF: 98 dB																																			
Maximum Output Continuous/Peak (SPL at 1 m)	HF: 126 dB/132 dB LF: 122 dB/128 dB	– LF: 128.5 dB/134.5 dB																																			
Nominal Coverage	H: 140° V: dependent on number of elements used	– –																																			
Cabinet Type	Ported, elliptical/trapezoidal	Vented subwoofer																																			
Enclosure Material	HIPS (high impact polystyrene) with UV protectant	18 mm Baltic birch plywood																																			
Finish	Available in black (WL2082-i BLK) or white (WL2082-i WHT) paintable	Available in black (WL118-sw BLK) or white (WL118-sw WHT) paintable																																			
Grille	Perforated, formed aluminum	16 gauge powder-coated steel with cloth backing																																			
Connectors	2 x NL8 in parallel	2 x NL8 in parallel/2 x NL4 in parallel																																			
Pin Outs	<table border="1"> <thead> <tr> <th>Pins</th> <th>Bi-Amp</th> <th>Tri-Amp</th> </tr> </thead> <tbody> <tr> <td>1+/1-</td> <td>N/A</td> <td>N/A</td> </tr> <tr> <td>2+/2-</td> <td>N/A</td> <td>LF2</td> </tr> <tr> <td>3+/3-</td> <td>LF</td> <td>LF1</td> </tr> <tr> <td>4+/4-</td> <td>HF</td> <td>HF</td> </tr> </tbody> </table>	Pins	Bi-Amp	Tri-Amp	1+/1-	N/A	N/A	2+/2-	N/A	LF2	3+/3-	LF	LF1	4+/4-	HF	HF	<table border="1"> <thead> <tr> <th colspan="2">Pins (NL8)</th> <th colspan="2">Pins (NL4)</th> </tr> </thead> <tbody> <tr> <td>1+/1-</td> <td>Sub</td> <td>1+/1-</td> <td>Sub</td> </tr> <tr> <td>2+/2-</td> <td>Pass thru (LF)</td> <td>2+/2-</td> <td>Pass thru</td> </tr> <tr> <td>3+/3-</td> <td>Pass thru (MF)</td> <td></td> <td></td> </tr> <tr> <td>4+/4-</td> <td>Pass thru (HF)</td> <td></td> <td></td> </tr> </tbody> </table>	Pins (NL8)		Pins (NL4)		1+/1-	Sub	1+/1-	Sub	2+/2-	Pass thru (LF)	2+/2-	Pass thru	3+/3-	Pass thru (MF)			4+/4-	Pass thru (HF)		
Pins	Bi-Amp	Tri-Amp																																			
1+/1-	N/A	N/A																																			
2+/2-	N/A	LF2																																			
3+/3-	LF	LF1																																			
4+/4-	HF	HF																																			
Pins (NL8)		Pins (NL4)																																			
1+/1-	Sub	1+/1-	Sub																																		
2+/2-	Pass thru (LF)	2+/2-	Pass thru																																		
3+/3-	Pass thru (MF)																																				
4+/4-	Pass thru (HF)																																				
Attachment Points	Integral, side plate adjustable rigging system, vertical splay adjustable in 1° increments from 0° – 10°	Integral, non-adjustable (straight array only)																																			
Weight (Net/Shipping)	37 lb (16.8 kg) / 45 lb (20.45 kg)	111 lb (50.4 kg) / 121 lb (55 kg)																																			
Dimensions (HWD)	11.8" x 27" x 13.4" (300 mm x 686 mm x 340 mm)	22.1" x 27.6" x 30.3" (562 mm x 702 mm x 771 mm)																																			
Accessories Available																																					
FB2082-i	Fly-bar for WL2082-i and WL118-sw. Available in black or white.																																				
EB2082-i	Extension bar, allows WL118-sw to be suspended behind WL2082-i. Available in black or white.																																				
PB2082-i	Pull-back bar for WL2082-i. For use when pulling back the bottom of the array is necessary to achieve the desired angle. Available in black or white.																																				
AB2082-i:	Angle bracket, allows greater vertical splay between WL2082-i and WL118-sw enclosures in ground stacked configurations. Available in black. Requires two brackets per array, sold individually.																																				
GS115-sw:	Ground stack kit for WL118-sw.																																				
QRP-KIT-1	Kit of four (4) Quick Release Pins for use in lieu of included bolts.																																				

1) 2 hours, IEC specified noise

Specifications subject to change without notice.

## WL2082-i Dimensions

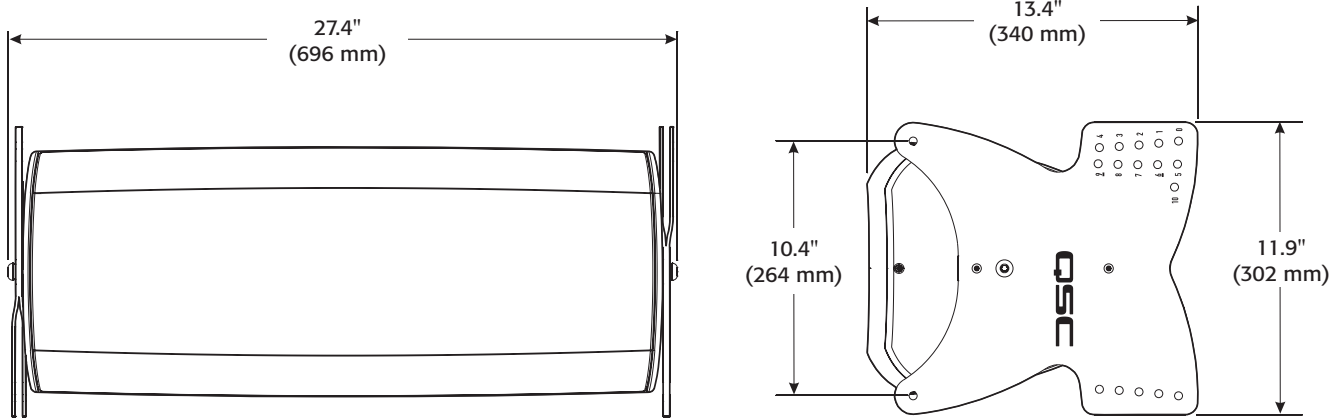

Working Load Limit Information				
Component	Weight	7:1 Design Factor	10:1 Design Factor	12:1 Design Factor
WL2082-i Loudspeaker	37 lb (16.8 kg)	889 lb (403.2 kg)	634 lb (288.3 kg)	445 lb (201.8 kg)

## WL118-sw Dimensions

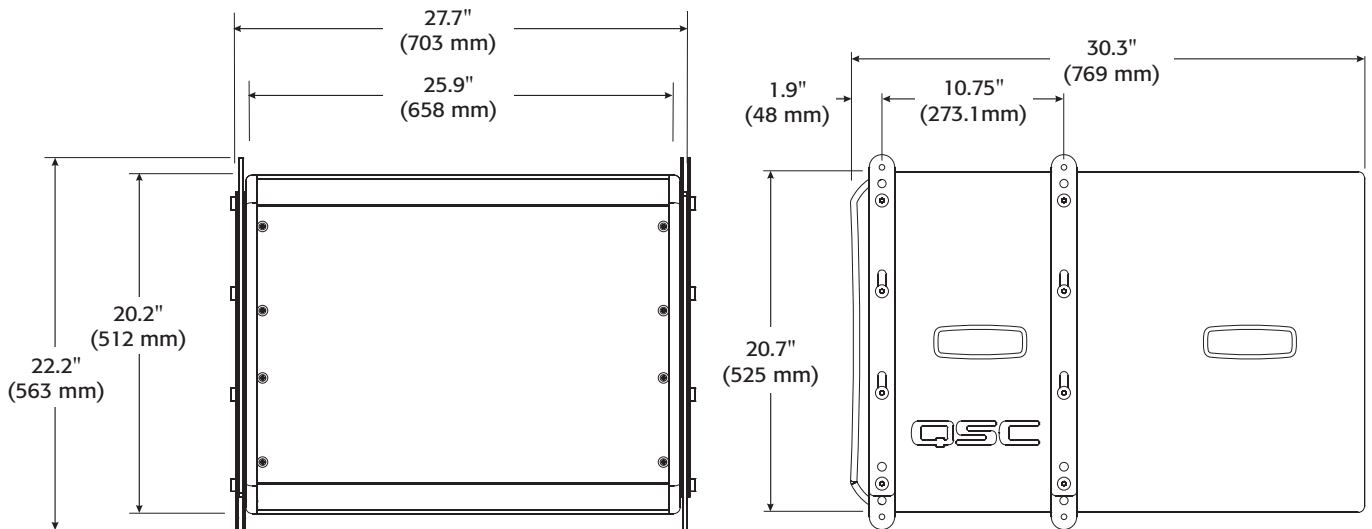

Working Load Limit Information				
Component	Weight	7:1 Design Factor	10:1 Design Factor	12:1 Design Factor
WL118-sw Loudspeaker	111 lb (50.5 kg)	740 lb (336.4 kg)	518 lb (235.5 kg)	432 lb (196.2 kg)

# EB2082-i Specifications

Material	Aluminum 6061-T6
Finish	Black powder coat (White optional)

Working Load Limit Information				
Component	Weight	7:1 Design Factor	10:1 Design Factor	12:1 Design Factor
EB2082-i Extension Bar	38 lb (17.3 kg)	1714 lb (779.2 kg)	1200 lb (545.5 kg)	1000 lb (454.5 kg)

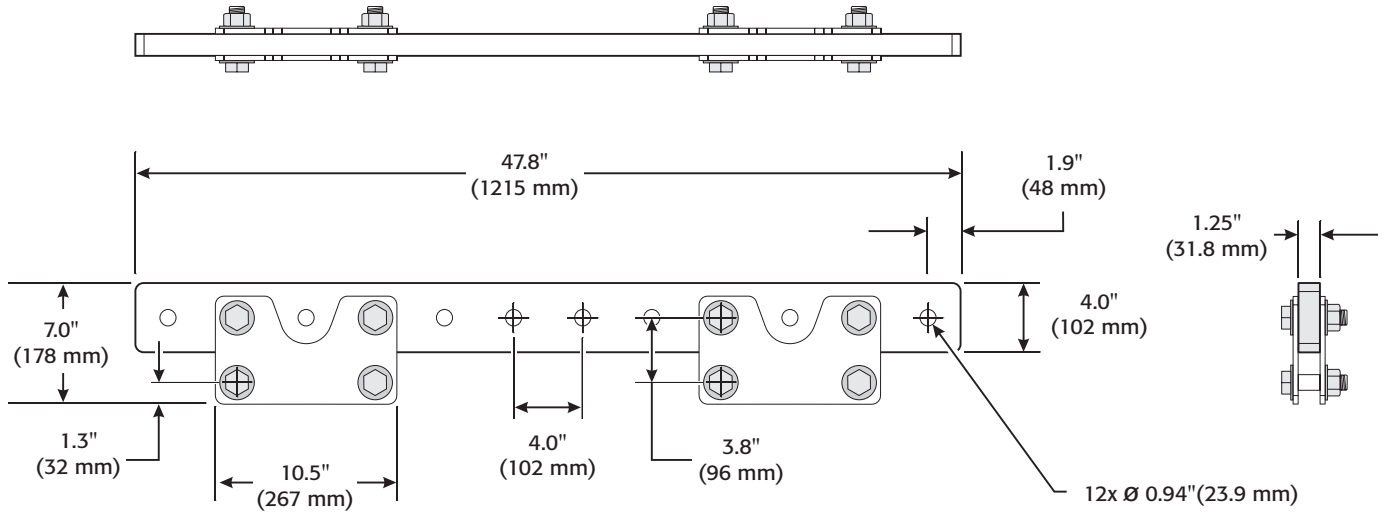

# FB2082-i Specifications

Material	Aluminum 6061-T6
Finish	Black powder coat (White optional)

Working Load Limit Information				
Component	Weight	7:1 Design Factor	10:1 Design Factor	12:1 Design Factor
FB2082-i Array Frame	17 lb (7.7 kg)	740 lb (336.4 kg)	518 lb (235.5 kg)	432 lb (196.2 kg)

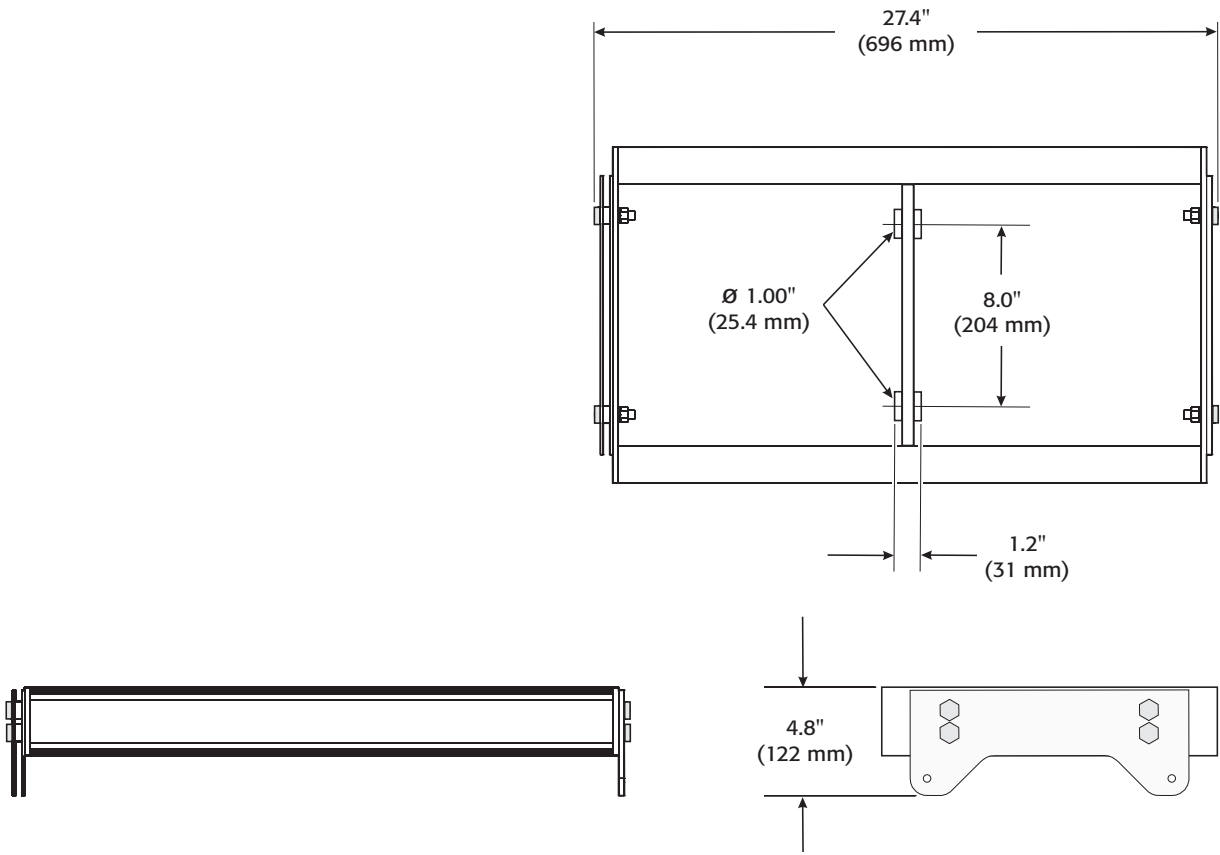



# PB2082-i Specifications

Material	Aluminum 6061-T6
Finish	Black powder coat (White optional)

Working Load Limit Information				
Component	Weight	7:1 Design Factor	10:1 Design Factor	12:1 Design Factor
PB2082-i Pull-Back Bar	6 lb (2.7 kg)	423 lb (192.2 kg)	296 lb (134.5 kg)	247 lb (112.1 kg)

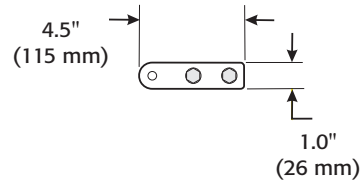
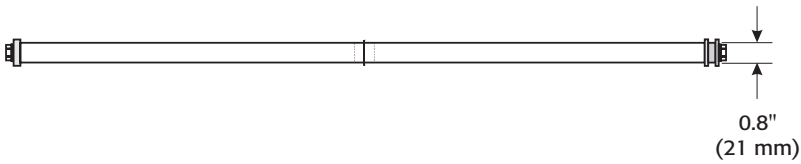
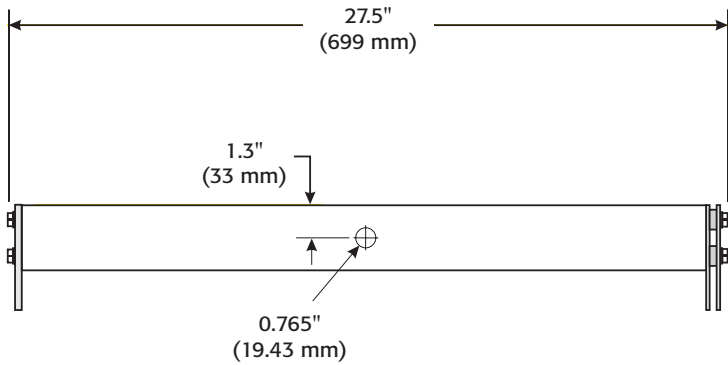

# GS115-sw Specifications

Material	Aluminum 6061-T6
Finish	Black powder coat (White optional)
Weight	5 lb (2.3 kg) per set

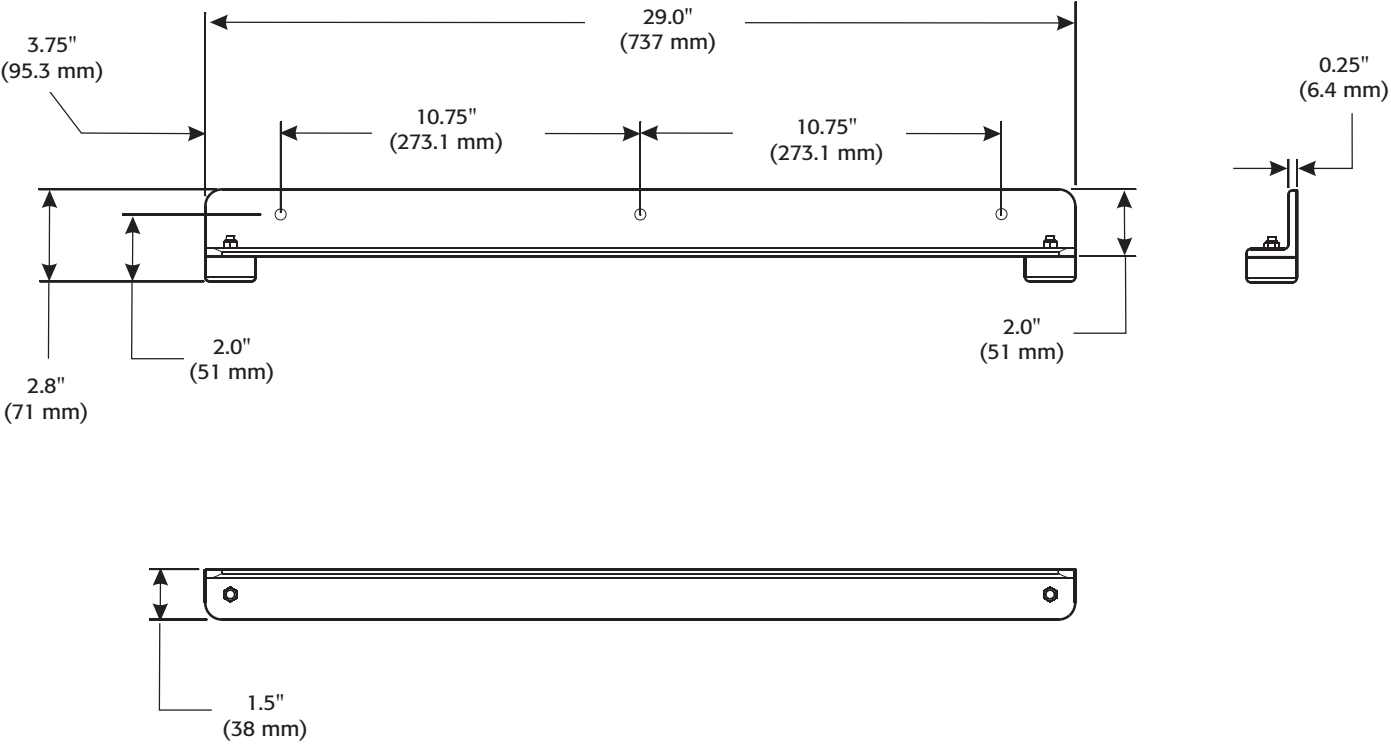



**Mailing Address:**

QSC Audio Products, LLC  
1675 MacArthur Boulevard  
Costa Mesa, CA 92626-1468 USA

**Telephone Numbers:**

Main Number: (714) 754-6175  
Sales & Marketing: (714) 957-7100 or toll free (USA only) (800) 854-4079  
Customer Service: (714) 957-7150 or toll free (USA only) (800) 772-2834

**Facsimile Numbers:**

Sales & Marketing FAX: (714) 754-6174  
Customer Service FAX: (714) 754-6173

**World Wide Web:**

[www.qscaudio.com](http://www.qscaudio.com)

**E-mail:**

[info@qscaudio.com](mailto:info@qscaudio.com)  
[service@qscaudio.com](mailto:service@qscaudio.com)

**QSC™**

Passionate About Sound