

NTS250 LOUDSPEAKER  
OWNER'S MANUAL

**BEAW**





# NTS250 Loudspeaker Owner's Manual

*Congratulations on the purchase of your new EAW loudspeaker. You now own one of the finest professional audio products available - the result of exceptional engineering and meticulous craftsmanship. Please read these instructions to get the maximum performance from your new loudspeaker.*

## 1 SAFETY PRECAUTIONS - READ THIS FIRST

### 1.1 Safety Instructions

Read and heed all warnings and safety instructions in the accompanying "EAW Loudspeaker Owner's Manual" before using this product. Failure to follow this precaution may result in damage, injury, or death.

**WARNING:** The loudspeaker is supplied with an AC mains power cable. Depending on the voltage model ordered, this cable is configured with the most common AC mains connector for that voltage. If the connector is not compatible with the local AC mains receptacle, employ a licensed electrician to re-configure the cable with the proper connector. Ensure that AC power supply has a properly grounded safety ground. Failure to follow this warning could cause damage, injury, or death.

## 1 CONSIGNES DE SÉCURITÉ - À LIRE EN PREMIER

### 1.1 Instructions Relative à la Sécurité

Lisez et respectez toutes les consignes de sécurité et les mises en garde fournies dans le manuel des enceintes EAW avant d'utiliser ce produit. Le non-respect de ces consignes et mises en garde peut entraîner des dommages aux équipements et des accidents aux personnes pouvant être fatals.

**ATTENTION:** L'enceinte est fournie avec un cordon secteur. Selon la tension du modèle commandé, ce câble est fourni avec la fiche la plus communément utilisée avec cette tension. Si la fiche n'est pas compatible avec les prises secteur de votre région, faites appel à un électricien agréé pour modifier le cordon secteur en fonction du format local. Vérifiez que la fiche secteur dispose d'une mise à la terre. Le non-respect de la mise à la terre peut entraîner des dommages aux équipements et des accidents aux personnes pouvant être fatals.

## 1. PRECAUZIONI DI SICUREZZA - DA LEGGERE PER PRIMO

### 1.1 Norme di Sicurezza

Prima di procedere con l'utilizzo del prodotto, leggere e rispettare ogni avvertenza e norma di sicurezza riportata nel "Manuale EAW Loudspeaker". Il mancato rispetto di ogni precauzione può causare danni all'apparecchiatura, nonché infortuni alle persone o la morte.

**ATTENZIONE:** Il diffusore è completo di cavo d'alimentazione ac fornito in dotazione. In base la voltaggio del modello di diffusore acquistato, il cavo è configurato con il connettore ac più adeguato. Nel caso in cui il connettore non sia compatibile con le prese di corrente adottate nell'area d'impiego, rivolgersi ad un elettricista qualificato per ri-configurare il cavo con il

connettore più appropriato. Assicurarsi che la presa di corrente sia adeguatamente collegata a terra. Il mancato rispetto di tali norme può causare danni all'apparecchiatura, nonché infortuni alle persone o la morte.

## **1. PRECAUCIONES DE SEGURIDAD - LEA ESTO PRIMERO**

### **1.1 Instrucciones de Seguridad**

Lea y observe todos los avisos e instrucciones de seguridad que aparecen en el "Manual de altavoces EAW" adjunto antes de usar este aparato. El no observar esta precaución puede dar lugar a averías en el aparato, daños en las personas o incluso la muerte.

**PRECAUCION:** El altavoz viene de fábrica con un cable de corriente. Dependiendo del voltaje que use el modelo solicitado, este cable estará configurado con el enchufe más habitual para ese tipo de corriente. Si ese enchufe no es compatible con su salida de corriente, contacte con un electricista profesional para que cambie el enchufe del cable por el tipo adecuado. Asegúrese de que la salida de corriente tenga una conexión a tierra adecuada. El no observar esta advertencia puede dar lugar a averías en el aparato, daños en las personas o incluso la muerte.

## **1. SICHERHEITSHINWEISE - LESEN SIE DIESEN ABSCHNITT ZUERST**

### **1.1 Sicherheitsanweisungen**

Lesen und beachten Sie alle Warnungen und Sicherheitsanweisungen der mitgelieferten "EAW Lautsprecher Bedienungsanleitung" vor der Benutzung des Produkts. Nichtbeachtung dieser Hinweise können möglicherweise zu Schäden am Equipment oder zu Verletzungen bzw. zum Tod von Personen führen.

**WARNUNG:** Der Lautsprecher wird mit einem Netzkabel geliefert. Abhängig von der jeweiligen Netzspannung wird das Kabel mit dem für die jeweilige Netzspannung gängigsten Netzstecker ausgeliefert. Sollte der Netzstecker nicht in Ihre Netzsteckdose passen, dann lassen Sie von einem zugelassenen Elektrobetrieb einen passenden Netzstecker montieren. Stellen Sie sicher, dass der Schutzkontakt der Netzsteckdose einen guten Kontakt zur Erde hat. Nichtbeachtung dieser Hinweise können möglicherweise zu Schäden am Equipment oder zu Verletzungen bzw. zum Tod von Personen führen.

## 1.2 EC Declaration of Conformity

Manufacturer: Eastern Acoustic Works -- USA

Declares that the following product(s) have been tested and passed all relevant requirements as described below by the appropriate European Directives as they apply to Professional Audio Products.

Product Model: NTS250  
Product Description: Self-powered loudspeaker

Safety Directive(s): EN 60065-2002  
EMC Directive(s): EN 55103-1 (Radiated/Conducted Emissions)  
EN 55103-2 (Radiated/Conducted Emissions)  
2004/108/EEC Directive

Low Voltage Directive: 72/23/EEC  
Markings Directive: 93/68/EEC

The Technical Report/Files is maintained at:

LOUD Technologies Inc.  
16220 Wood-Red Road NE  
Woodinville, WA 98072 USA

Authorized Representative:	Tel: +1 425 892 6500
Walter Hsu	Tel: +1 425 402 6259
Compliance Manager	Fax: +1 425 487 4337
Loud Technologies, Inc.	e-mail: info@eaw.com

Issued: March, 2010

## 1.3 FCC Compliance

This equipment has been tested and found to comply with the limits for a Class A digital device, pursuant to Part 15 of the FCC Rules. These limits are designed to provide reasonable protection against harmful interference when the equipment is operated in a commercial environment. This equipment generates, uses, and can radiate radio frequency energy and, if not installed and used in accordance with the instruction manual, may cause harmful interference to radio communications. Operation of this equipment in a residential area is likely to cause harmful interference in which case the user will be required to correct the interference at his own expense.

**CAUTION:** Changes or modifications not expressly approved by the LOUD Technologies could void the user's authority to operate the equipment.

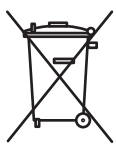

*Correct disposal of this product.* This symbol indicates that this product should not be disposed of with your waste, according to the WEEE Directive (2002/96/EC) and your national law. This product should be handed over to an authorized collection site for recycling waste electrical and electronic equipment (EEE). Improper handling of this type of waste could have a possible negative impact on the environment and human health due to potentially hazardous substances that are generally associated with EEE. At the same time, your cooperation in the correct disposal of this product will contribute to the effective usage of the natural resources. For more information about where you can drop off your waste equipment for recycling, please contact your local city office, waste authority, or your household waste disposal service.

# CONTENTS

1	SAFETY PRECAUTIONS - READ THIS FIRST	iii
1.1	Safety Instructions	iii
1	CONSIGNES DE SÉCURITÉ - À LIRE EN PREMIER	iii
1.1	Instructions Relative à la Sécurité	iii
1.	PRECAUZIONI DI SICUREZZA - DA LEGGERE PER PRIMO	iii
1.1	Norme di Sicurezza	iii
1.	PRECAUCIONES DE SEGURIDAD - LEA ESTO PRIMERO	iv
1.1	Instrucciones de Seguridad	iv
1.	SICHERHEITSHINWEISE - LESEN SIE DIESEN ABSCHNITT ZUERST	iv
1.1	Sicherheitsanweisungen	iv
1.2	EC Declaration of Conformity	v
1.3	FCC Compliance	v
	CONTENTS	vi
2	UNPACKING	1
2.1	Contents	1
3	QUICK START	2
3.1	Rear Panel Connectors and Controls	2
3.2	Initial Control Settings	3
3.3	Audio Connection	3
3.4	AC Mains Connection	3
3.5	Adjusting the Output Level	3
4	OVERVIEW	4
4.1	Introduction	4
4.2	Description	4
4.3	Amplification	5
4.4	Using the Loudspeaker	5
5	ARRAY DESIGN	5
5.1	Software Program	5
6	ELECTRICAL INSTALLATION	5
6.1	AC Mains	5
6.2	AC Mains Connection	6
6.3	AC Mains Cable	7
6.3	Cordon secteur	7
6.3	Cavo D'alimentazione AC	7
6.3	Cable de alimentacione	7
6.3	Netzkabel	8
6.4	Power On / Off	8
6.5	AC Mains Voltage	8
6.6	Power Cord Receptacle	9
6.7	Grounding	9
6.8	AC Loop Connector	9
6.9	Operating Temperature	10
6.10	Input Connections	10
6.11	Network Configurations	11
7	ARRAY OPERATION	13
7.1	Overview	13
7.2	Engineering Design	13
7.3	Operating Controls	13
7.4	Signal Processing	14
7.5	User Adjustable DSP	14
8	RIGGING & HANDLING	15
8.1	Rigging Overview	15
8.2	Rigging Warnings	16
8.3	Permanent Installation Suspension	16
9	SERVICE, INSPECTION, and MAINTENANCE	18
9.1	General Service	18
9.2	Rigging Service	18
9.3	Basic Field Troubleshooting and Repair	18
9.4	Inspection and Maintenance	18
9.5	Contacting EAW	18
10	BLOCK DIAGRAM	19
10.1	Signal Flow Diagram	19
10.2	Block Diagram	20

## 2 UNPACKING

### 2.1 Contents

Qty	Item
1	NTS250 Loudspeaker
1	Power Cord (dependent on product's AC mains rating) 115 V - Neutrik® PowerCon® to Nema 15R plug 9.5 ft / 2.9 m or 230 V - Neutrik PowerCon to male Schuko plug 8 ft / 2.5 m
1	Power Cord AC Loop (Neutrik PowerCon to Neutrik PowerCon)
1	USB Cable 6 ft / 2 m
1	NTS250 Owner's Manual (this document)
1	EAW Loudspeaker Owner's Manual
1	Warranty Card
1	RJ45 Ethernet Cable 4 ft / 0.6 m (Neutrik® EtherCon®)

### 3 QUICK START

If you are in a hurry or are knowledgeable about using powered loudspeakers, these Quick Start instructions provide the details particular to the NTS Series loudspeakers.

#### 3.1 Rear Panel Connectors and Controls

- |   |  |
|---|--|
| 1 AC Mains Input:                       | Connect to AC mains supply as labeled.                   |
| 2 AC Mains Loop Through                 | Loop AC mains to four (4) additional NTS250 (1440 W MAX) |
| 3 AC Loop Circuit Breaker               | User resettable, 10 A (115 V), 5 A (230 V)               |
| 4 Enable/Standby Contacts               | Closed = Standby, Open = On                              |
| 5 System Gain                           | Provides Gain for system balance                         |
| 6 Rear Spkr ASP                         | Provides cancellation using multiple NTS250              |
| 7 USB Port                              | Connect to a PC for controlling with EAWPilot            |
| 8 Dual U-Net Connectors                 | Connection and loop through for U-Net network            |
| 9 Input Level Status Indicators         | Indicators for signal present, limiter active, and clip  |
| 10 Amplifier Status Indicator           | Indicator for normal and fault status                    |
| 11 Audio Input Connector                | Connect analog or AES/EBU digital input signals          |
| 12 Input Selector Switch and Indicators | Select type of input signal, analog, AES/EBU, or U-Net   |
| 13 Audio Loop Through Connector         | Loop input signal to additional NTS250 or other device   |

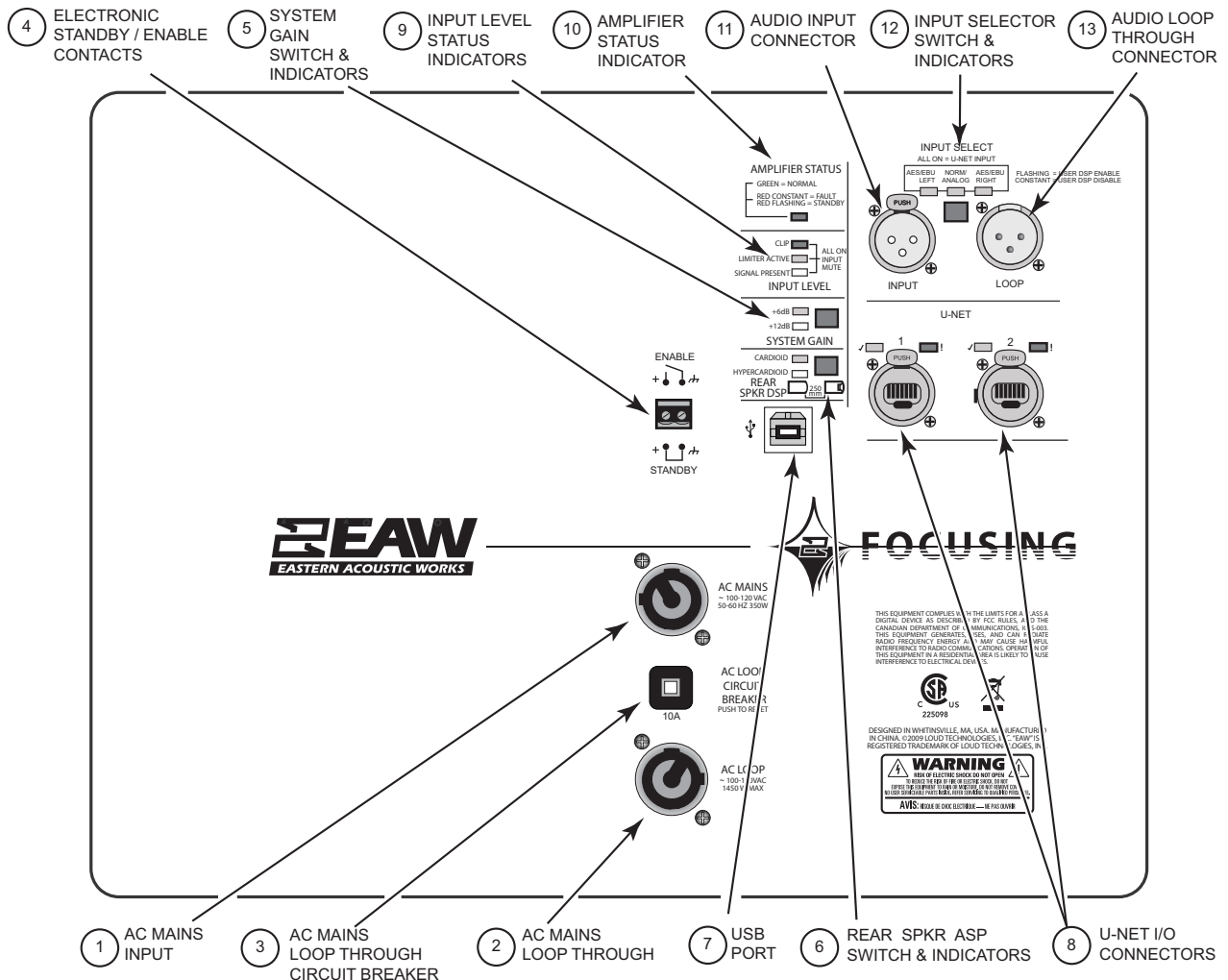



### 3.1.1 BUTTON PRESS/HOLD FEATURES

*While Powered:*

Hold Input Select button for five (5) seconds --- user DSP bypass/enable  
Hold all three buttons for five (5) seconds --- lock/unlock buttons  
(disables rear panel button; software controls still active)

*On power up:*

Hold Input Select and System Gain buttons --- reset all settings to factory default  
(all user settings will be overwritten)  
Hold System Gain and Rear Spkr DSP buttons --- put into boot mode  
(only used for troubleshooting)

## 3.2 Initial Control Settings

Use these nominal settings for the rear panel switches. These are multi-state “soft” switches which control software functions. Repeatedly pressing each switch cycles through its multiple states.

CONTROL	SETTING	LED INDICATION
System Gain	Normal	Both LED's off
Rear Spkr DSP	Normal	Both LED's off
Input Select	Normal	Center LED on (Norm/Analog)

**WARNING:** Before connecting an NTS loudspeaker to the AC mains supply, completely turn down the input signal to the loudspeaker using the signal source's output level (master volume control or other output level control). If not, there could be excessive and possibly damaging sound levels from the loudspeaker when energized.

## 3.3 Audio Connection

Connect the output from your line-level signal source to the XLR-3F Input connector on the rear panel. This is an electronically balanced input. Use the loop through connector to daisy-chain the signal to additional NTS250s.

## 3.4 AC Mains Connection

Connect one of the supplied AC mains cord to the Neutrik PowerCon receptacle on the rear of the loudspeaker. Use the appropriate cord for the AC mains voltage as labeled on the loudspeaker: nominal 115 V or 230 V. Connect the other end to the AC mains supply receptacle. If necessary, have a qualified electrician change the AC mains cord plug as required for compatibility with the local AC mains receptacle.

**CAUTION:** There is no power switch on the loudspeaker. When connected to the AC mains, the loudspeaker will be fully operational, with the output level controlled by the signal source feeding the loudspeaker.

## 3.5 Adjusting the Output Level

With a source program playing, gradually turn up the level of your signal source until the desired volume is reached but below the point where the CLIP and/or LIMITER lights illuminate.

**CAUTION:** If there is no sound, turn down the signal source's output level before investigating the problem. Do this to avoid excessive and possibly damaging sound levels from the loudspeaker.

## **4 OVERVIEW**

### **4.1 Introduction**

The NTS250 loudspeaker is intended for professional use. The construction, components, and hardware have been designed to provide robust, reliable performance for its intended application. Please ensure that you fully understand proper installation and operation before use.

### **4.2 Description**

The NTS250 powered subwoofer (much like the NTL720 compact line array) is a comprehensively integrated system. It has been architected to serve as a general purpose companion subwoofer for any high end EAW system or even for a competitive main system, but as the name suggests it is an obvious choice to use in conjunction with the NTL720. This professional, high output yet compact premium subwoofer unites two highly efficient, 4 inch voice coil, neodymium 15 inch woofers (arranged in a push-pull variant of the SB1000 family transducer configuration), 2000W of amplification, powerful DSP to both optimize the product and provide user accessible processing via EAW Pilot, our proprietary U-Net audio network, a native rigging system (that is additionally kit adaptable for direct connection above an NTL720 array), push button 2 box cardioid and hyper-cardioid configurability, and the durable RoadCoat cabinet finish within a single integrated system.

## 4.3 Amplification

As is true of all professional loudspeaker systems, the performance of the NTS250 Series loudspeakers depends on amplifiers delivering an adequate supply of clean power. To maximize performance, the loudspeakers have powerful, built-in, high-efficiency amplifiers. NTS250s are bi-amplified, meaning each woofer has its own amplification and internal DSP. Even though extremely lightweight, these amplifiers provide the exceptionally high output capabilities required for professional applications.

## 4.4 Using the Loudspeaker

You will need to perform the following general tasks to properly put the loudspeaker into service. The details for each task are provided in this manual.

1. If suspended, design and install a rigging or mounting system to support the array in its intended location and aimed in the desired direction.
2. Connect a line-level audio signal to the loudspeakers in the array.
3. Connect the loudspeakers to an AC mains supply as specified on the loudspeakers.
4. Connect the computer control to the loudspeaker's USB port.
5. Set-up and adjust overall system gain and signal processing, as needed to maximize the array's performance for the application.
6. Provide training to operate the loudspeakers within their limits.
7. Provide regular inspection and maintenance to maintain the integrity of the installation and the performance of the loudspeakers.

# 5 ARRAY DESIGN

## 5.1 Software Program

### 5.1.1 EAWPILOT

EAWPilot is software for controlling the digital signal processing (DSP) for multiple EAW products. Use the EAWpilot to apply user-adjustable signal processing to the overall array. The interface provides standard DSP functions, including parametric equalization, high/low shelving, low- and high-pass filtering, level, and signal delay.

### 5.1.3 COMPUTER REQUIREMENTS

EAWPilot and NTS250 Array Wizard require an IBM compatible PC with the Windows® 98, Windows® 98SE, Windows® 2000, Windows® ME, Windows® XP, and Windows NT® and Vista® operating systems.. It is not designed to work with Windows® 3.x, Windows® 95, or Macintosh® operating systems.

# 6 ELECTRICAL INSTALLATION

## 6.1 AC Mains

There are two NTS250 models, differing only in the AC mains supply:

NTS250 (115 V) Nominal AC mains: 100 V to 120 V, 50 Hz to 60 Hz

NTS250 (230 V) Nominal AC mains: 220 V to 240 V, 50 Hz to 60 Hz

## 6.2 AC Mains Connection

This section details the requirements for the AC mains connection required by each NTS250 loudspeaker.

### 6.2.1 AC MAINS SUPPLY

**WARNING:** Read all instruction and cautionary notes concerning electrical power in the “EAW Loudspeaker Owner’s Manual”.

**DANGER:** Ensure that the AC mains voltage matches the voltage rating listed on the loudspeaker next to the AC mains connector. DO NOT APPLY 230 V MAINS POWER IF THE VOLTAGE RATING ON THE LOUDSPEAKER IS 115 V. IMMEDIATE AND CATASTROPHIC DAMAGE TO THE LOUDSPEAKER WILL RESULT AND MAY CAUSE A FIRE HAZARD, SERIOUS PERSONAL INJURY, OR DEATH.

### 6.2.1 ALIMENTATION SECTEUR

**ATTENTION:** Lisez toutes les instructions et notes de sécurité sur l'alimentation secteur, dans le mode d'emploi de l'enceinte EAW.

**DANGER:** Vérifiez la tension secteur de l'enceinte, sérigraphiée à côté de l'embase secteur de l'enceinte. NE PAS APPLIQUER UNE TENSION SECTEUR DE 230 V SI L'ENCEINTE EST DE 115 V. LES DOMMAGES À L'ENCEINTE SERAIENT IMMÉDIATS ET IRRÉVERSIBLES - DE PLUS, CES DOMMAGES PEUVENT ÊTRE SOURCE D'INCENDIE, DE BLESSURES GRAVES VOIRE FATALES.

### 6.2.1 ALIMENTAZIONE AC

**ATTENZIONE:** Leggere tutte le istruzioni e le avvertene riguardanti l'alimentazione elettrica, incluse nel Manuale EAW Loudspeaker.

**PERICOLO:** Assicurarsi che il voltaggio dell'alimentazione utilizzata nell'area in cui si intende utilizzare il diffusore, corrisponda al voltaggio riportato nel pannello posteriore del diffusore, vicino alla connessione di alimentazione AC. NON UTILIZZARE UN VOLTAGGIO DI 230 V SE NEL DIFFUSORE VIENE INDICATO UN VOLTAGGIO DI 115 V. IL DANNO PER IL DIFFUSORE SAREBBE IMMEDIATO E MOLTO SERIO, E POTREBBE CAUSARE INCENDI, DANNI FISICIALE PERSONE E LA MORTE.

### 6.2.1 FUENTE DE ALIMENTACIÓN

**PRECAUCION:** Lea todas las instrucciones y advertencias relativas a la corriente eléctrica que aparecen en el manual de altavoces EAW.

**PELIGRO:** Asegúrese que el voltaje de la salida de corriente coincida co el que aparece indicado en el propio altavoz al lado del conector de entrada de corriente. NO APLIQUE UN VOLTAJE DE 230 V SI SU ALTAVOZ FUNCIONA CON UN VOLTAJE DE ENTRADA DE 115 V. EL NO CUMPLIR ESTO PUEDE DAR LUGAR A DAÑOS INMEDIATOS Y CATASTROFICOS EN E ALTAVOZ, ASI COMO AL RIESGO DE INCENDIOS, DAÑOS SERIOS O INCLUSO LA MUERTE.

### 6.2.1 NETZSTROMVERSORGUNG

**WARNUNG:** Lesen Sie alle Anweisungen und Sicherheitshinweise bezüglich der Netzspannung in der EAW Lautsprecher Bedienungsanleitung.

**GEFAHR:** Versichern Sie sch, dass die zur Verfügung stehende Netzspannung mit der auf der Rückseite des Lautsprechers angegebenen Spannung übereinstimmt. SCHLIESSEN SIE KEINE

230 V NETZSPANNUNG AN, WENN DER LAUTSPRECHER FÜR 115 V KONFIGURIERT IST. SOFORTIGE, KATASTROPHALE SCHÄDENSIND DIE FOLGE. ES BESTEHT DIE GEFAHR VON FEUER, VERLETZUNG ODER TOD.

Each NTS250 model is manufactured for a particular nominal AC mains voltage, either 115 V or 230 V. Provide the loudspeaker with AC mains circuit capable of:

<b>Model</b>	<b>115 V</b>	<b>230 V</b>
<b>Range</b>	220 V to 240 V	220 V to 240 V
<b>Frequency</b>	50 Hz to 60 Hz	50 Hz to 60 Hz
<b>Maximum Current</b>	3A/350 W	1.5 A/350 W

### 6.3 AC Mains Cable

The supplied AC mains cables mate with the Neutrik PowerCon NAC3MPA AC MAINS jack on the loudspeaker.

**WARNING:** Ensure that AC power supply has a properly grounded safety ground. Failure to follow this warning could cause equipment damage, injury, or death.

**CAUTION:** The supplied AC mains plug may not be appropriate for local AC mains receptacles. If not, have a qualified electrician remove the existing AC mains plug and install a plug appropriate for the ac mains supply receptacle and following all local codes.

**CAUTION:** If an extension cord is used for the AC mains, use only a cord rated for at least 1800 VA.

### 6.3 Cordon secteur

Le cordon secteur fourni est équipé d'une fiche Neutrik PowerCon NAC3FCA adaptée à l'embase secteur Neutrik PowerCon NAC3MPA de l'enceinte.

**ATTENTION :** Il se peut que le format de la fiche secteur ne corresponde pas à celui de votre situation géographique. Dans ce cas, faites appel à un électricien agréé pour qu'il remplace la fiche par une autre du bon format. Respectez les normes électriques de câblage locales.

**ATTENTION:** Assurez-vous que la ligne secteur dispose d'une terre. Le non-respect de cette précaution peut entraîner des dommages aux équipements et des accidents aux personnes pouvant être fatals.

### 6.3 Cavo d'alimentazione AC

Il cavo Neutrik PowerCon NAC3FCA fornito in dotazione è collegabile al connettore Neutrik PowerCon NAC3MPAAC MAINS presente nel diffusore.

**CAUTELA:** Il connettore del cavo d'alimentazione AC fornito in dotazione potrebbe non essere adeguato per le prese di corrente impiegate nell'area in cui il diffusore viene utilizzato. In questo caso, contattare un elettricista qualificato per sostituire la presa di corrente con una dotata di connessione adeguata. Per il cablaggio, occorre seguire la codifica corretta utilizzata nell'area d'utilizzo.

**ATTENZIONE:** Assicurarsi che la presa d'alimentazione sia correttamente collegata a terra. Il mancato rispetto di tali avvertenze potrebbe causare danni all'apparechiatura, nonché infortuni alle persone o la morte.

### 6.3 Cable de alimentación

El enchufe Neutrik PowerCon NAC3FCA incluido en el cable encaja en la toma de entrada Neutrik PowerCon NAC3MPAAC MAINS del altavoz.

**PRECAUCION:** El enchufe que viene en el cable de alimentación incluido puede que no encaje en las salidas de corriente de su zona. Si ocurre esto, contacte con un electricista profesional para que sustituya el enchufe problemático y lo cambie por uno adecuado para la salida de corriente. Compruebe que se sigan todas las normativas de seguridad aplicables.

**PRECAUCION:** Asegúrese que la fuente de alimentación tenga una conexión a tierra correcta. El no cumplir con esta advertencia puede dar lugar a daños en el equipo, en las personas que lo manejen o incluso la muerte.

### 6.3 NETZKABEL

Das mitgelieferte Kabel kann an der Seite mit dem Neutrik PowerCon NAC3FCA in die PowerCon NAC3MPA Buchse auf der Rückseite des Lautsprechers gesteckt werden.

**VORSICHT:** Das mitgelieferte Netzkabel besitzt möglicherweise einen Netzstecker, der nicht in Ihre Steckdose passt. In diesem Fall können Sie sich von einem zugelassenen Elektrobetrieb einen passenden Netzstecker unter Berücksichtigung der jeweils gültigen Vorschriften montieren lassen.

**WARNUNG:** Stellen Sie sicher, dass der Schutzleiter der Netzsteckdose eine gute Verbindung zur Erde hat. Nichtbeachtung dieses Hinweises kann zu Schäden am Equipment, zu Verletzungen oder zum Tod führen.

### 6.4 Power On / Off

**CAUTION:** There is no power switch on the loudspeaker. When connected to the AC mains, the loudspeaker will be energized and fully operational with the output level controlled by the signal source feeding the loudspeaker.

#### 6.4.1 POWER ON SEQUENCE:

When energized, the loudspeaker's electronics will initialize. The initialization sequence will last between 1.5 and 2 seconds. The indications for normal initialization are:

1. All LEDs will illuminate steadily, starting from right to left: INPUT SELECT, U-NET, AMPLIFIER STATUS, INPUT LEVEL, SYSTEM GAIN, REAR SPKR DSP.
2. The LEDs will then illuminate according to the current status of the functions they indicate.

If it is desired to completely power off (de-energize) the loudspeaker, a conveniently located AC mains disconnect must be supplied or the power cable must be unplugged from the AC mains supply.

### 6.5 AC Mains Voltage

**CAUTION:** There is no power switch on the loudspeaker. When connected to the AC mains the loudspeaker will be fully operational, with the output level controlled by the signal source feeding the loudspeaker.

The NTS250 is compatible with these nominal AC mains: 100 V, 110 V, 115 V, 120 V, 220 V, 230 V, and 240 V at 50 Hz to 60 Hz.

Connect the supplied AC mains cord to the Neutrik PowerCon socket on the rear of the loudspeaker. Use the cord with the Nema 15P for nominal 115 V AC mains. Use the cord with the Schuko plug for nominal 230 V AC mains. Connect the other end to an AC mains supply receptacle, nominal 115 V or 230 V as labeled on the loudspeaker. If necessary, have a qualified electrician change the cable plug as required for compatibility with the local AC mains receptacle.

**CAUTION:** To maintain all compliance ratings, keep AC input voltage between 100 V to 120 V or 220 V to 240 V.

Replacement 115 V AC mains cord part number: 0021435  
 Replacement 230 V AC mains cord part number: 0015224

## 6.6 POWER CORD RECEPTACLE

The Neutrik Powercon AC mains inlet on the rear panel accepts the detachable power cords supplied with the unit.

**120 V AC mains:** Use the 3-wire grounded ac cord with the NEMA 5-15 plug.

**230 V AC mains:** Use the 3-wire grounded ac cord with the Schuko plug.

**CAUTION:** It is the user’s responsibility to provide a proper AC mains plug for any AC mains outlet configuration that differs from those supplied with the product.

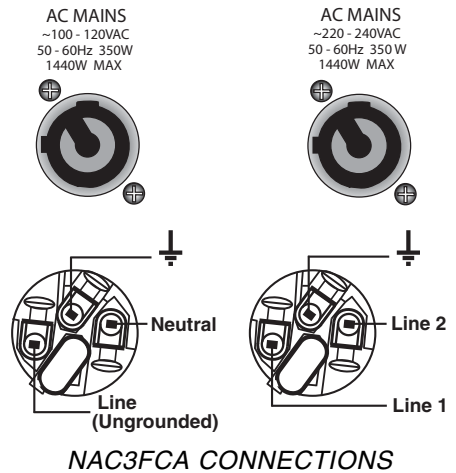

Conductors 115 V Models		Conductors 230 V Models	
Line or Ungrounded	Black	Line 1	Brown
Neutral or Grounded	White	Line 2	Blue
Safety Ground	Green	Safety Ground	Green/Yellow Stripping

AC MAINS WIRE COLOR CODE

## 6.7 GROUNDING

The chassis of this product is grounded through the grounding conductor of the power cord. To avoid electric shock, plug the power cord into a properly wired and grounded receptacle before making any connections to or operating the product.

**DANGER:** This equipment must be operated with the power cord grounding conductor connected to a properly grounded AC outlet. Do not disconnect, “lift,” or otherwise remove this ground connection. Without this connection, accessible parts, including knobs and controls that may appear to be insulated, can render an electric shock that can cause injury or death to operating personnel.

Connect the supplied AC mains cord to the PowerCon jack on the rear of the loudspeaker. The PowerCon system uses a locking connector. To lock, twist 1/4 turn clockwise after fully inserting it into the receptacle. Then, connect the other end of the cable to the AC mains supply receptacle. This will energize the loudspeaker.

## 6.8 AC LOOP Connector

The Neutrik Powercon AC mains and AC loop connectors are wired in parallel to provide an AC mains inlet and outlet on each NTS250.

The blue AC mains inlet mates with a Neutrik Powercon NACFC3A (supplied). The white AC mains outlet mates with a Neutrik Powercon NACFC3B (also supplied). Therefore, to loop the AC mains from enclosure to enclosure, connect the AC mains jumper cable as shown. Up to four (4) NTS250s can be looped in this fashion.

Use the AC loop connector to daisy-chain AC mains power from one enclosure to another. The maximum, continuous load must not exceed 10 A for the 115 V version and 5 A for the 230 V version..

**NOTE:** The circuit breaker only protects the AC Loop outlet, not the AC mains connector. If the continuous load connected to the AC Loop outlet exceeds the rated load, the circuit breaker will trip. For this situation, reduce the connected load and then manually reset the circuit breaker.

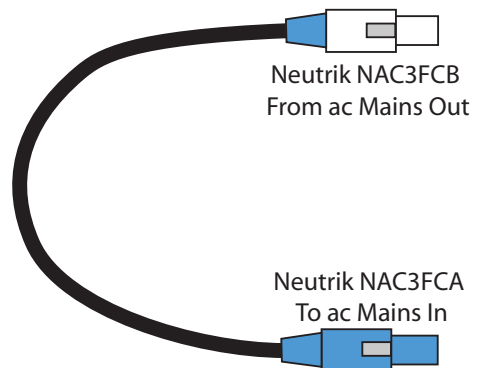

Recommended cable length for connecting vertically adjacent enclosures = 300 mm to 450 mm / 12 in to 18 in

## 6.9 Operating Temperature

The operating temperature ranges is 32° F to 131° F / 0°C to 55° C.

## 6.10 Input Connections

### 6.10.1 ANALOG SIGNAL INPUT CONNECTION

The two XLR-type input connectors on the rear of each NTS250, one female and one male, are designed for professional audio signal levels, nominally 0 dBu (= 0.775 V). Normally, use the female XLR as the signal input. Use the male XLR as a loop-thru output to connect the same signal input to additional NTS250s.

To use these connectors for analog audio input signals, repeatedly press the associated momentary INPUT SELECT switch, cycling through the LED indications until only the NORM/ANALOG LED is illuminated.

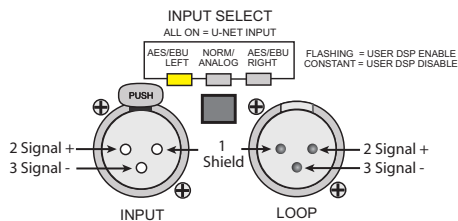

Cable: 2 conductor plus shield  
Mating Connector: XLR-3 male

PIN 1 Shield  
PIN 2 Plus / Hot  
PIN 3 Minus / Cold

### 6.10.2 DIGITAL SIGNAL INPUT CONNECTION

The two XLR-type connectors used for analog audio signals are also used for digital audio signals. These are designed for the AES/EBU digital signal (AES3 Standard). Use the female XLR as the signal input. Use the male XLR as a loop-thru output to connect the same signal input to additional NTS250s.

To use these connectors for digital audio input signals, repeatedly press the associated momentary INPUT SELECT switch, cycling through the LED indications until either the AES/EBU Ch 1 or the AES/EBU Ch 2 LED is illuminated.

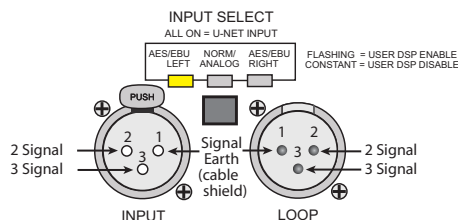

Channel 1 and Channel 2 are also referred to as Subframe 1 and Subframe 2.

Cable: 2 conductor plus shield  
Mating Connector: XLR-3 male

PIN 1 Signal earth (shield)  
PIN 2 Signal  
PIN 3 Signal

**IMPORTANT:** Looping an AES/EBU signal to another NTS250 or other audio device's analog input will result in audible noise at potentially high levels. Make sure the downstream service input accepts an AES/EBU (AES3) digital input signal.

### 6.10.3 USB CONNECTION

The standard USB connection on the rear of the NTS250 is designed to connect a computer with the EAWPilot control program installed. Subsequent NTS250s are connected using the U-Net ports. EAWPilot provides user-adjustable control over individual elements in the array and over the array as a whole.

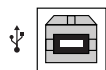



Port Type: USB 1.1  
 Cable: Standard USB 2.0 Cable Type A to B supplied (maximum 15 ft / 3 m without active repeaters. A 6 ft / 2 m USB cable is supplied)  
 Mating Connector: USB type "B" connector

#### 6.10.4 U-NET NETWORK CONNECTION

The two, identical, locking Neutrik EtherCon connectors on the rear of each NTS250 combine a RJ45 connector with a locking shell. They are designed for connecting EAW's audio and control signals between additional NTS250s and other U-Net enabled devices. Either connector may be used as the ports are bi-directional. In addition they auto-sense the cable wiring configuration (standard or crossover).

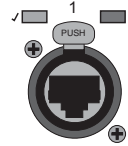

Cable: Ethernet CAT-5 or better (300 feet / 91 meters)  
 Mating Connector: RJ45 with or without Neutrik NE8MC cable carrier  
 Wiring Configuration: Standard or crossover cable (ports auto-sense cable configuration)  
 Green Status LED: Indicates communication is established between two devices  
 Red Status LED: Indicates a network error. A solid red LED indicates there is an error somewhere in the network. A blinking red LED indicates the device that is causing the error.

To use the U-Net input signal, repeatedly press the associated momentary INPUT SELECT switch cycling through the LED indications until all three LEDs are illuminated.

**Note:** EAWPilot must be used to select the U-Net audio channel and configure the U-Net audio routing.

### 6.11 Networking Configurations

NTS250s are equipped for networking both control signals and audio signals through the U-Net connections. Audio can be routed into, out of, and through each device over U-Net and devices can be controlled individually or as an array. EAWPilot is required to configure the U-Net networking of the NTS250 and its operation is described in the EAWPilot Help file (Help>EAWPilot Help).

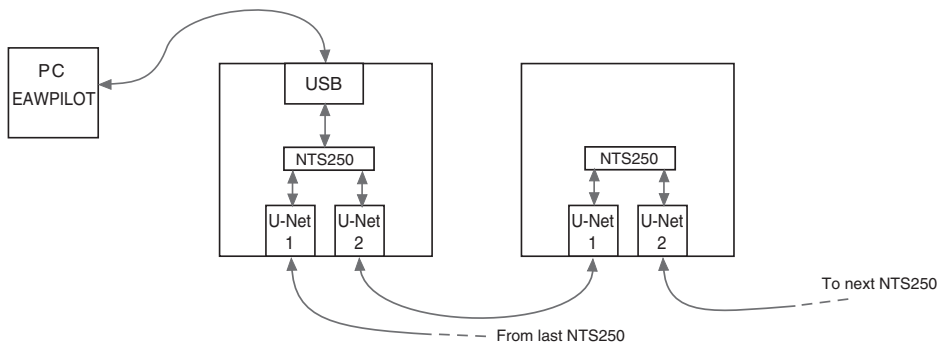

#### 6.11.1 CONNECTING MULTIPLE NTS250s IN A U-Net CHAIN

Connect the USB port in the rear panel of the first NTS250 to a computer with the EAWPilot control program installed. Connect one of the U-Net ports on the rear panel of the first NTS250 to a U-Net port on the next NTS250. Continue daisy-chaining the remaining NTS250 U-Net ports until they are all connected. An analog or digital input signal to the first NTS250 can then be routed over U-Net to all subsequent units. This is done using EAWPilot control software.

## 6.11.2 CONNECTING ONE OR MORE NTS250s TO A COMPUTER USING A UX8800

Use the UX8800's front panel Ethernet port and the supplied Ethernet crossover cable to connect directly to a computer's 10, 10/100, or 100 Mbps Ethernet port. A user-supplied, shorter or longer cable may be substituted. The UX8800's Ethernet port is auto-negotiating, meaning it will automatically exchange information over a link about speed and duplex capabilities and negotiate these to the highest common denominator.

**CAUTION:** an Ethernet crossover cable is required when connecting two Ethernet ports in the same layer of the OSI model (Open Systems Intercommunication Reference Model). A computer's Ethernet Port, meaning its NIC (network interface card), and the UX8800 are both OSI layer 3 ports. Therefore, an Ethernet crossover cable is **REQUIRED** when directly connecting the UX8800 to a computer's NIC. An Ethernet crossover cable reverses transmit and receive pin connections between the connectors at each end of the cable.

Connect one of the U-Net ports on the UX8800's rear panel to a U-Net port on the NTS250. If there are more than one NTS250, connect the other U-Net port on the NTS250 to the next NTS250, and so on. This configuration is used to rout any number of UX8800 outputs to the NTS250s on the U-Net chain. Again, EAWPilot is used for U-Net configuration.

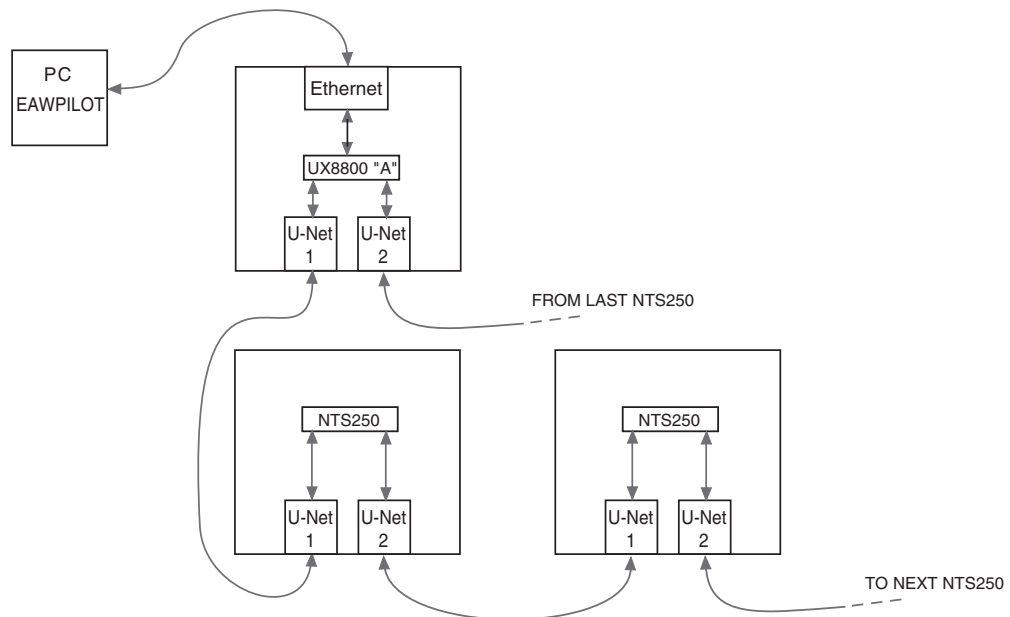

It is recommended that you connect the first free U-Net port to the first NTS250. A ring is created so the audio and control signals have two paths along the network, and the integrity of the network is maintained in the event that one NTS250 should go offline.

There is no requirement to connect Port 1 to Port 2 or vice versa. Signals are sent out both U-Net ports bidirectionally so any port can be connected to any other port. It is recommended, however, that the NTS250s be connected sequentially, top down or bottom up in an array.

# 7 ARRAY OPERATION

## 7.1 Overview

The operation of a NTS250 Series system involves:

1. Understanding the principles on which it operates.
2. How to electronically configure it for a specific task.

## 7.2 Engineering Design

The NTS250 packs a big sound and an ever bigger set of user definable features into a compact and powerful active subwoofer.

The new advanced feature set on the input controls sport a simple push button configuration offering cancellation at 180 degrees in a cardioid pattern or cancellation at 135 degrees in a hyper-cardioid pattern between two NTS250 subwoofers.

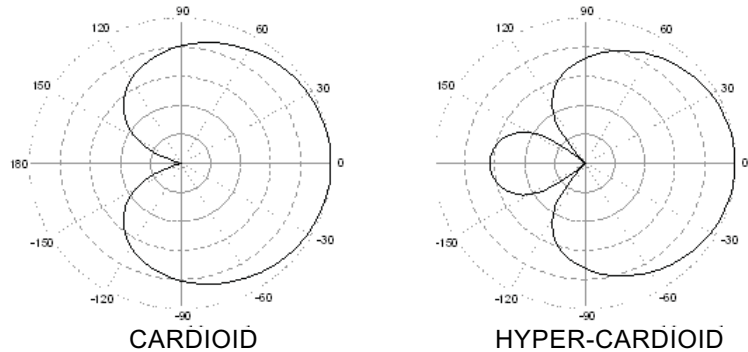

From this revolutionary fast set up optimized for the NTS250 the flexibility to perform pattern control from an array continues. Users can interface with the onboard processing of the NTS250 through EAW Pilot software and tailor the output pattern of multiple NTS250 subwoofers to match defined cancellation angles and a center frequency of cancellation. With the customary compliment of equalization filters, gain adjustments, delay settings, and polarity controls found standard in EAW NT series products, the NTS250 subwoofer is packed with features not usually associated with self powered subs. Innovative design offers a full spectrum of input options including analogue, AES, and EAW’s U-Net audio network over Cat-5 cable. Configuring arrays of subs is easy via U-Net’s discrete 64 channels of audio and 64 channels of control supporting a full line of EAW products by inexpensively and efficiently connecting devices linked through U-Net. Not only does the NTS250 provide unique flexibility in cardioid arrays, it can be flown in powerful compact line arrays. Combining the interconnectivity of U-net, the ability to be flown in arrays, and when used with a special adaptor bar the NTS250 completes a full NTL720 line array.

This professional, high output yet compact premium subwoofer unites two highly efficient, 4 inch voice coil, neodymium 15 inch woofers (arranged in a push-pull variant of the SB1000 family transducer configuration), 2000W of amplification, powerful DSP, U-Net audio network, a native rigging system, push button 2 box cardioid and hyper-cardioid configurability, and durable RoadCoat cabinet finish within a single integrated system. This is so much more than just another subwoofer. It is one of the most sophisticated subs in the world.

## 7.3 Operating Controls

The operating controls on the NTS250 rear panel are momentary contact, “soft” switches. This means that they control software that does the actual switching with status lights indicating the switch “position.” Pressing a switch repeatedly will cycle through its available options.

### 7.3.1 INPUT SELECT

Repeatedly press the switch between the XLR input connectors to cycle through and select the desired input signal type.

INPUT SELECT ALL ON = U-NET INPUT	LED STATUS		
	OFF	ON	OFF
<b>NORM/ANALOG</b>	OFF	ON	OFF
<b>AES/EBU CH1</b>	ON	OFF	OFF
<b>AES/EBU CH2</b>	OFF	OFF	ON
<b>U-NET</b>	ON	ON	ON

Press and hold the switch for five seconds to bypass the user-adjustable DSP (accessible from EAWPilot). Repeat to enable the user DSP.

LED flashing = DSP enabled  
 LED constant = DSP disabled

**NOTE:** U-Net can be selected with the Input Select switch, but the U-Net audio channel and routing must be configured using the EAWPilot software application.

### 7.3.2 STANDBY JUMPER

Use these dry contacts to remotely control the operational status of the loudspeaker’s electronics. Short the contacts to place the amplifiers in standby mode. This disables the high voltage rails powering the amplifiers, muting the system and reducing power consumption when the system is not being used. Open the contacts for full function. The Amplifier Status LED flashes red when the amplifiers are in standby mode.



CONTACTS	ELECTRONICS STATUS
OPEN	FULLY FUNCTIONAL
CLOSED	STANDBY

**NOTE:** The NTS250 ships with the mating connector for these contacts installed. If this feature will not be used, the connector may be removed.

### 7.3.3 AC LOOP CIRCUIT BREAKER

This is a resettable circuit breaker that protects the NTS250 from passing excessive current through the AC Loop connector. Connect no more than three NTS250s to the AC Loop connector of a single NTS250. If the circuit breaker should trip, the first NTS250 will continue to operate, but all the NTS250s connected via the AC Loop connector will stop working. Determine what caused the circuit breaker to trip and remedy the situation before resetting the circuit breaker.

## 7.4 Signal Processing

### 7.4.1 FACTORY SIGNAL PROCESSING SETTINGS

NTS250 array performance, in terms of frequency response, beamwidth consistency, output level capability, and wavefront coherency is dependent on the crossover and other processing settings fixed within the built-in digital processing. These settings are determined from extensive measurements in typical venues. As such, they are required in order for the array to perform correctly and should normally provide excellent results in a variety of venues.

## 7.5 User Adjustable DSP

### 7.5.1 EQUALIZATION

The EAWPilot software application provides access to standard, user-adjustable DSP functions to modify the overall performance of the array to accommodate a particular program content, venue characteristics, or personal taste in voicing. These include low-pass filter, high-pass filter, shelving and parametric EQ, gain, delay, and polarity. It also provides access to signal routing (Input Select and U-Net Send), as well as System Gain and Rear Spkr DSP settings for each individual loudspeaker.

## 7.5.2 OPERATING LIMITS

While the NTS250 processing includes robust driver and amplifier protection algorithms and circuits, it is ultimately the responsibility of the audio system operator to operate the loudspeakers within their capabilities. This is the only way to ensure that loudspeakers are not stressed beyond their limits to the point of damage or failure.

Operation beyond their capabilities usually includes, but is not limited to, one or more of the following conditions:

- Severe amplifier clipping
- Noticeable distortion
- Mechanical noise (such as cones bottoming out)

The NTS250s have both Limiter Active and Clip indicators. A suitable means for determining if these indicators are active is highly recommended. At a minimum, the operator should have a meter display calibrated to indicate the level where the NTS250s Limiting and Clipping point are and thus be near to exceeding their capabilities.

As an alternative to a mixing console or other meter display, the EAWPilot provides real-time meter display of the NTS250 levels.

## 8. RIGGING & HANDLING

NTS250 arrays may be suspended via M10 mounting points or the accessory FB152 Fly Bar, ground-stacked, or used as pole mount bases. This manual will cover subwoofer suspension using M10 mounting points and pole mounting applications. Suspension using the FB152 Fly Bar and ground-stacking applications are detailed in the FB152 Rigging & Ground Stack Instructions. Both documents recommend rigging and handling methods for most situations. Specific situations may require other methods. It is the user's responsibility to determine the viability and safety for alternate methods and to implement them accordingly.

### 8.1 RIGGING OVERVIEW

The NTS250 subwoofer has two (2) Rigging Tubes on each enclosure side – four (4) in total. Each Tube contains a captive Latch which slides down and attaches to the Rigging Tubes of an adjacent enclosure via a 46 mm / 1.75 in Quick Release Pin – see Figure to the right.

**DANGER:** Ensure each Quick Release Pin used in assembling an array is fully inserted and engaged into the Tube and Bar holes. Only use the supplied Quick Release Pins or equal. Pins of different lengths, diameter, or material will compromise the structural integrity of the rigging system and may result in damage to the equipment, injury, or death.

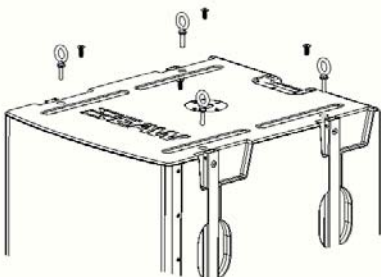
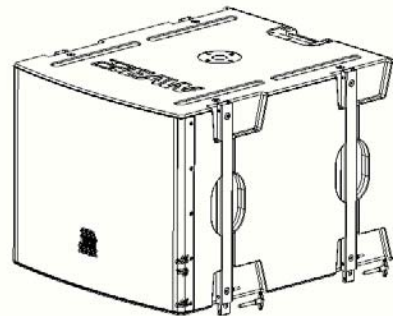

Each product also includes four (4) M10 threaded Permanent Installation (PI) suspension points on enclosure top and bottom. The figure to the left illustrates their locations in the NTS250 top panel. M10 forged shoulder eyebolts or similar load-rated hardware may be used in these points when deploying NTS250 subwoofers in permanent installation applications.

## 8.2 RIGGING WARNINGS

**WARNING:** Suspending anything, especially overhead of people, should be done with extreme caution. Always engage the services of a certified professional who is qualified to determine and implement the requirements for overhead rigging. Only persons with the knowledge of proper hardware and safe rigging techniques should attempt to suspend NTS250 arrays overhead. Failure to follow these precautions may result in damage to the equipment, injury, or death.

**DANGER:** When suspending or stacking NTS250s, avoid placing any parts of the body between the enclosures or between an enclosure and the Fly Bar. Always use the integral handles to lift or position enclosures. Failure to follow this precaution may result in damage to the equipment, injury, or death.

**CAUTION:** Because an NTS250 weighs approximately 58 kg / 127 lb, always use two people or mechanical assistance to lift a NTS250. Always use proper lifting techniques to avoid injury.

Please see Section 4 “Rigging / Mounting / Suspension” and Section 5 “Rigging Design” in the accompanying EAW Loudspeaker Owner’s Manual for additional, important rigging information.

## 8.3 PERMANENT INSTALLATION SUSPENSION

### 8.3.1 PI ARRAY WORKING LOAD LIMIT (WLL)

**WARNING:** When four (4) M10 threaded Permanent Installation (PI) suspension points are used the array Working Load Limit (WLL), Total Vertical Pull, is limited to ten (10) NTS250 Subwoofers. In order to obtain full WLL, all four (4) M10 threaded Permanent Installation (PI) suspension points must be vertically attached to the support structure, and the array must be suspended vertically. Any other method of attachment or hanging configuration will de-rate the WLL and maximum number of subwoofers.

WEIGHTS: NTS250 Loudspeaker: 58 kg / 127 lb

### 8.3.2 A NOTE ON EYEBOLTS

Load-rated eyebolts are commonly used with threaded suspension points. Eyebolts used with NTS250 subwoofers must possess the following attributes:

Type:	Shoulder pattern
Thread Size:	M10 x 1.5
Shank Length:	Minimum 35 mm
WLL:	Use appropriately rated eyebolt for application.



**CAUTION:** Eyebolt Working Load Limits are significantly de-rated when angular lifts are applied. If an application requires an angular lift greater than 45 degrees a swivel hoist ring or similar fitting must be used – see Figure to the right. These fittings have full swivel and pivot action, which helps avoids side loads.

### 8.3.3 PERMANENT INSTALLATION OVERVIEW

The NTS250 enclosures may be suspended in a permanent installation without the accessory FB152 Fly Bar. In these applications user-supplied M10 x 1.5 x 35 mm forged shoulder eyebolts or load-rated equivalent are installed in an array’s top enclosure.

The following instructions pertain specifically to eyebolt installation and array handling when using said eyebolts. Join enclosures within an array by following the procedures described in the accompanying FB152 Rigging & Ground Stack Instructions.

### 8.3.4 NTS250 ARRAYS

- Using a 6 mm Allen wrench, remove the four (4) flat head screws from the top panel of the uppermost array enclosure. These screws are adjacent to the side Rigging Tubes, see figure to the right.
- Thread four (4) user-supplied M10 x 1.5 x 38mm forged shoulder eyebolts through the exposed mounting points, making sure the eyebolt shoulders are firmly seated against the enclosure. Orient each eyebolt so that the load will be applied within the plane of the eye.
- Attach the hoist mechanism and cables to the eyebolts with user-supplied Screw Pin Anchor Shackles. Minimum allowable Shackle size is 0.75 T, 9mm / 0.31 in.
- Hoist the array so that it is slightly off the ground. Confirm that array face is vertical. If the array is not vertical, bring array down and adjust hoist mechanism and cables before hoisting the array to the desired trim height.

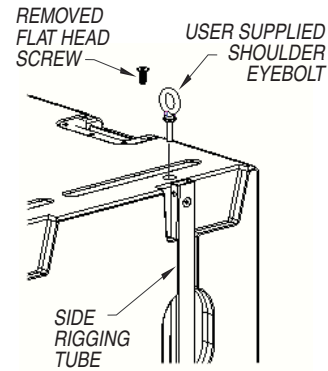

### 8.3.5 POLE MOUNTING

Up to two (2) NTS250 subwoofers may be used as a base for pole-mountable loudspeakers. In this configuration a 35 mm/1.38 in diameter loudspeaker pole is inserted between the NTS250s pole cup and the pole cup of the loudspeaker. The pole may be a fixed length or height adjustable. In either case it must be rated to support the weight of the pole mounted loudspeaker.

EAW's model SPM100 height-adjustable pole is an ideal companion, see figure to the right. To use:

- Stack up to two (2) NTS250 loudspeakers on a level, stable surface.
- Insert the SPM100 pole in the NTS250's pole mount cup.
- Remove the pole's Quick Release Pin from its stored position and loosen the clamp handle.
- Raise the inner pole to the desired height and insert the Quick Release pin in the nearest through-hole.
- Lower the inner pole so that the pin is resting atop the clamp mechanism.
- Tighten the clamp handle so that the inner pole cannot easily rotate. Do not over-tighten; the Quick Release Pin should bear the weight of the pole-mounted loudspeaker.

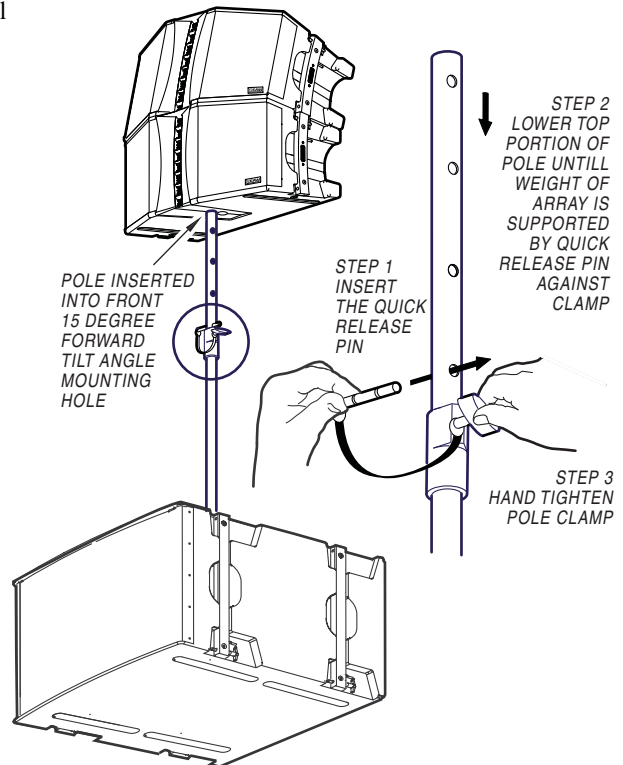

**CAUTION:** All enclosures must be securely pinned together. Be sure that the subwoofers are stabilized and secured from falling over or being accidentally pushed over.

## **9 SERVICE, INSPECTION, AND MAINTENANCE**

### **9.1 General Service**

For any faults that cannot be field-repaired as noted below, contact the EAW Service Department listed in Section 9.5.2 to determine the appropriate action. This applies to both warranty and non-warranty faults.

### **9.2 Rigging Service**

Because of the potential, serious consequences and liabilities due to faulty rigging, contact EAW to determine the appropriate service solution for any rigging hardware problems.

### **9.3 Basic Field Troubleshooting and Repair**

Each NTS250 loudspeaker has an input panel, internal components and wiring, transducers, and an enclosure. Troubleshooting for various performance problems usually involves isolating the problem to one of these areas:

1. Transducers
2. Internal electronics and wiring
3. Enclosure and integral hardware

If no problems can be traced to any of these items, look for problems with external electronics or cabling. Troubleshooting these items is beyond the scope of this manual.

### **9.4 Inspection and Maintenance**

Refer to Section 11 in the EAW Loudspeaker Owner's Manual (included) for complete information on inspecting and maintaining EAW loudspeakers and rigging systems.

### **9.5 Contacting EAW**

We have tried to answer any questions you may have about the NTS250 in this manual and in the EAWPilot help files. Should you need further assistance, please do not hesitate to contact us. You can contact us in several different ways.

#### **9.5.1 OPERATING QUESTIONS**

For questions about configuring or operating the loudspeakers, contact:

EAW Applications Support Group  
Tel 508-234-6158  
Tel 800-992-5013 (USA only)  
Fax 508-234-6479  
e-mail [asg@eaw.com](mailto:asg@eaw.com)

#### **9.5.2 SERVICE INFORMATION**

For questions about troubleshooting or servicing a NTS250, contact:

EAW Service Department  
Shipping: One Main Street Building 11  
Whitinsville, MA 01588 USA  
Tel 508-234-6001  
Tel 800-992-6001 (USA only)  
Fax 508-234-3776  
e-mail [service@eaw.com](mailto:service@eaw.com)



### 9.5.3 GENERAL

For all other information:

Mail	Eastern Acoustic Works One Main Street Whitinsville, MA 01588 USA
Tel	508-234-6158
Tel	800-992-5013 (USA only)
Fax	508-234-6479
Web Site	<a href="http://www.eaw.com">http://www.eaw.com</a>
e-mail	<a href="mailto:info@eaw.com">info@eaw.com</a>

## 10 BLOCK DIAGRAM

### 10.1 System Flow Diagram

The block diagram shows the signal flow for two NTS250s.

As can be seen, the audio input signal, AC mains, and the U-Net signal can be looped from one NTS250 to additional NTS250s.

While the audio cable and U-Net cables can be looped to any number of additional NTS250s, the maximum for the AC mains looping is four additional NTS250. This is limited by a resettable circuit breaker in-line with the AC mains loop jack.

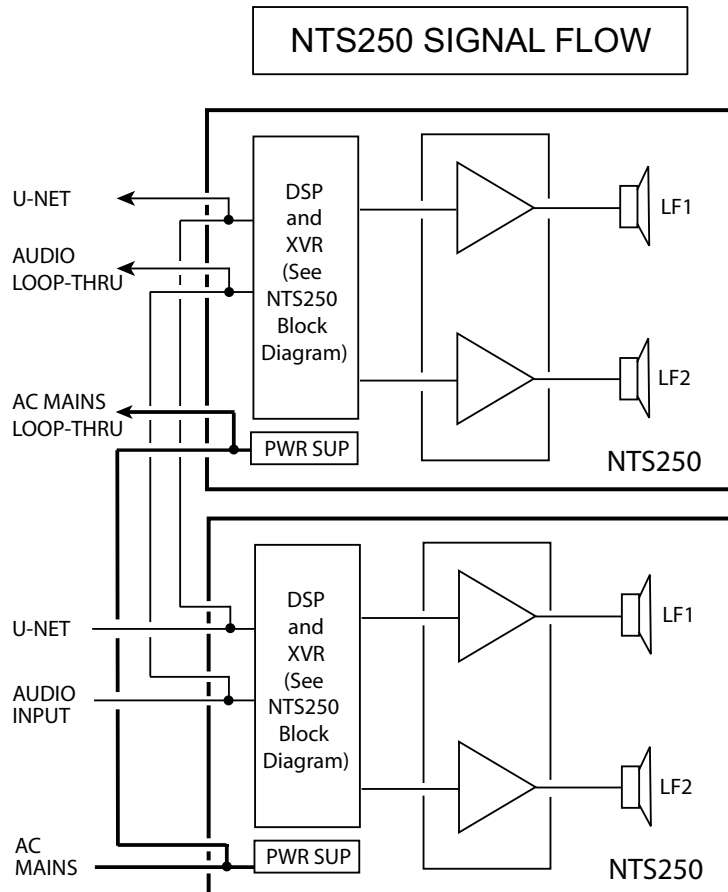

## 10.2 Block diagram

The block diagram shows the DSP blocks for the NTS250. The user DSP is configurable using the EAWPilot software application. The present DSP is not user-configurable and is designed to optimize the performance of the NTS250.

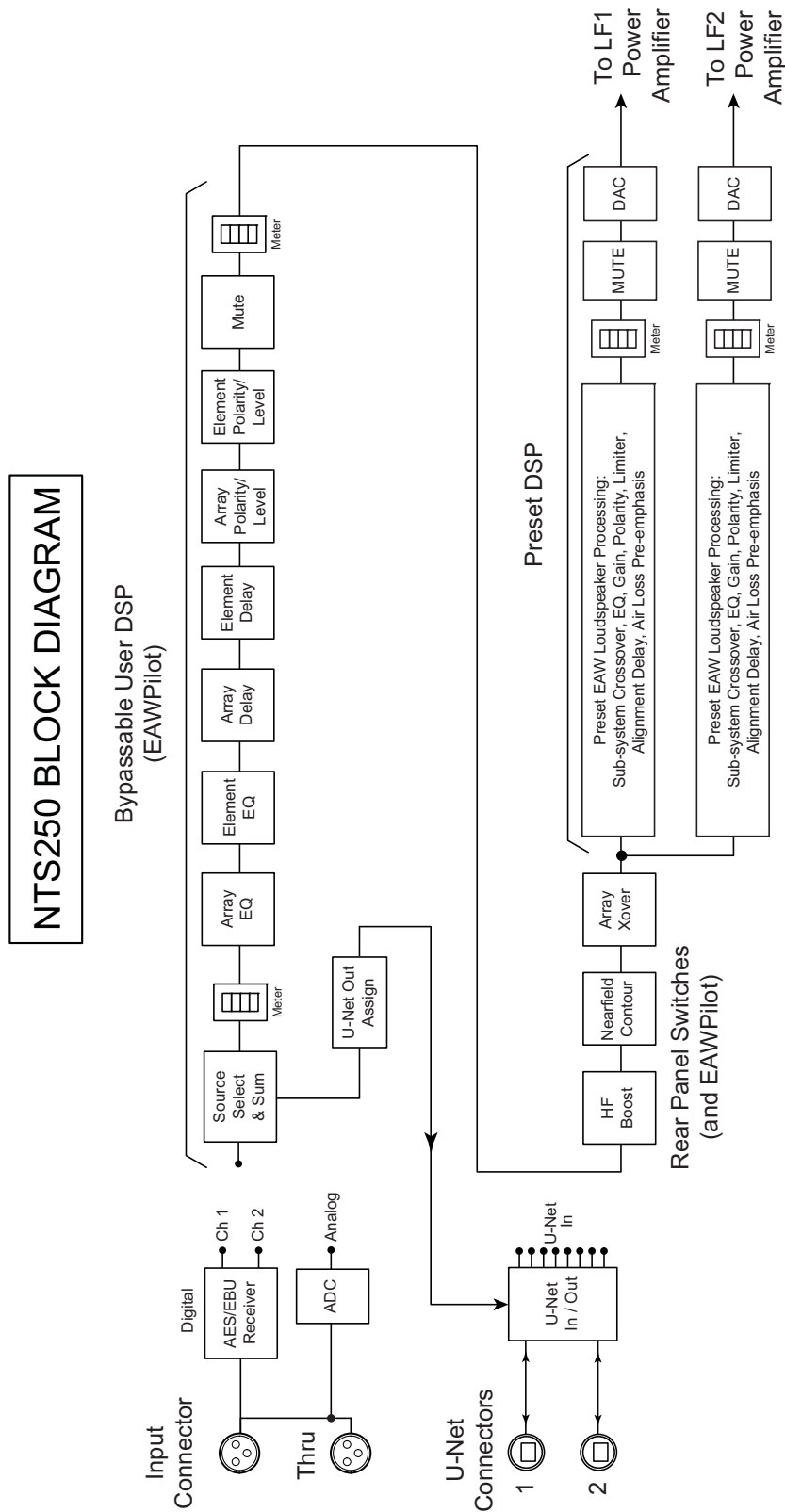

This page left intentionally blank.



One Main Street Whitinsville, MA, USA 01588  
TEL 508-234-6158 FAX 508-234-6479  
© 2010 LOUD Technologies Inc. All rights reserved.  
P/N RD0511 Rev A March 2010