

REV	DESCRIPTION	APVD/DATE
3	UPDATED FORMAT PER ECO # 3955. JRM 8/17/99	KFH 8/24/99
D	ORACLE REVISION CONVERSION DRAWING WAS REV 3 PER ECO 5151 SS 8/1/01	ES 1/07/02

NOTES:

1. SYMBOL ● INDICATES MOUNTING POINT, 3/8-16 THREADED HOLE (NUT PLATE).
2. SYMBOL ⊙ INDICATED RUBBER FOOT
3. SYMBOL ⊕ INDICATES CENTER OF BALANCE.
4. WEIGHT APPROX. 52 LBS
5. SHIPPING WEIGHT APPROX. 60 LBS

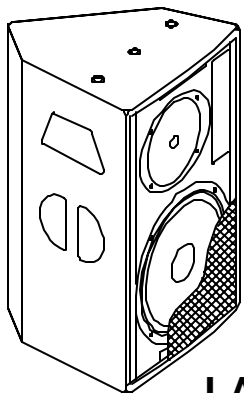
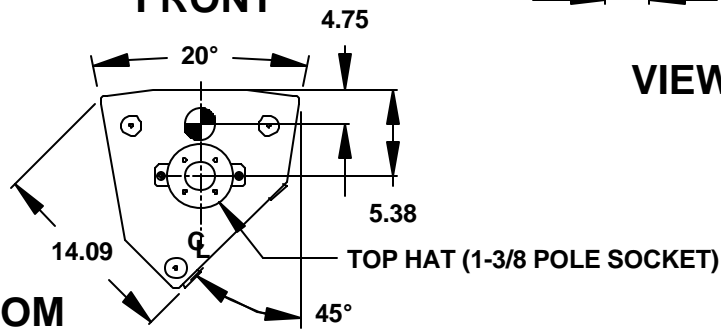
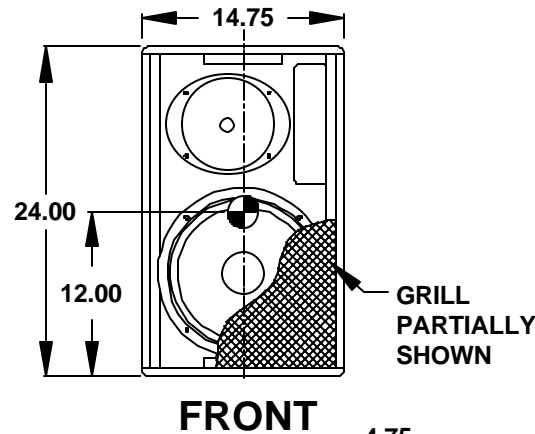
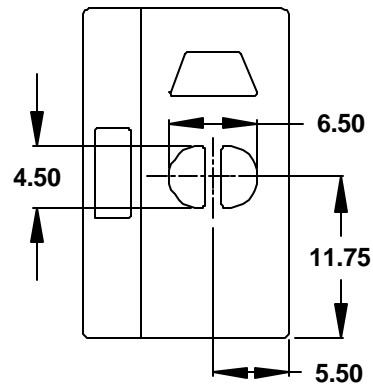
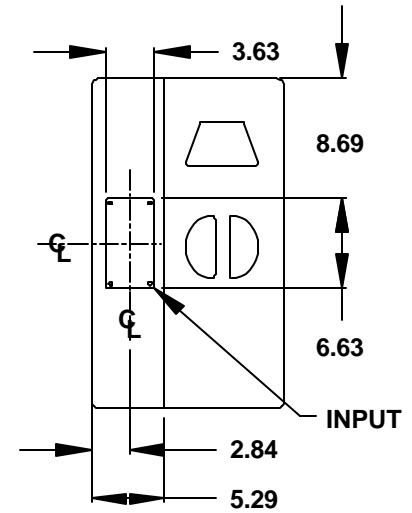
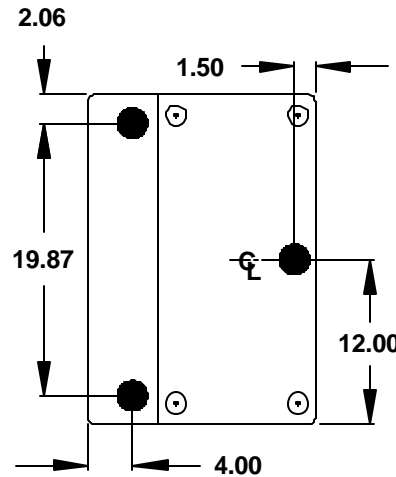
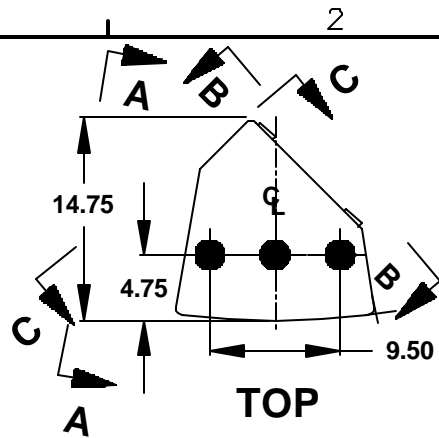

LA212

DOCUMENT CONTROL PER SPECIFICATION 4.5 201

<p>THIRD ANGLE PROJECTION</p>	<p>UNLESS OTHERWISE SPECIFIED, ALL DIMENSIONS ARE IN INCHES</p> <p>TOLERANCE IN INCHES</p> <p>.XX ± .13</p> <p>ANGLES ± 1°</p> <p>(X XX) = REF DIMS NO TOLERANCE IMPLIED</p> <p>T.S.C.=THEORETICAL SHARP CORNER</p> <p>DIMENSIONS ACROSS CENTERLINES TO BE SYMMETRICAL</p>	<p>STATUS: PRODUCTION</p>		<p>EAW EASTERN ACOUSTIC WORKS ONE MAIN STREET WHITINSVILLE, MA 01568 USA</p>	
		<p>APPROVALS</p> <p>DRAWN: F LECOURL</p> <p>CHECKED: JWB</p> <p>DES ENG: MAL</p> <p>MFG ENG: JS</p>	<p>DATE</p> <p>12/24/99</p> <p>2/12/96</p> <p>2/12/96</p> <p>2/12/96</p>		<p>TITLE:</p> <p>CABINET/FINISHED/ LA212 [MECHANICAL SPECIFICATION]</p>
<p>THIS DRAWING IS THE PROPERTY OF EAW AND SHALL NOT BE COPIED, REPRODUCED, OR USED AS THE BASIS FOR MANUFACTURE OR SALE OF APPARATUS WITHOUT WRITTEN AUTHORIZATION. DO NOT SCALE DRAWING.</p>			<p>A</p>	<p>SHEET 1 OF 1</p>	<p>SCALE: 1 TO 14</p>
<p>DRAWING NUMBER: 510299</p>				<p>REVISION D</p>	