

REV	DESCRIPTION	APVD/DATE
0	UPGRADE TO PRODUCTION PER DSR 00-1486 SS 12/18/00	KFH 1/16/01
A	ORACLE REVISION CONVERSION DRAWING WAS REV 0 PER ECO 5151 SS 6/20/01	SS 6/20/01

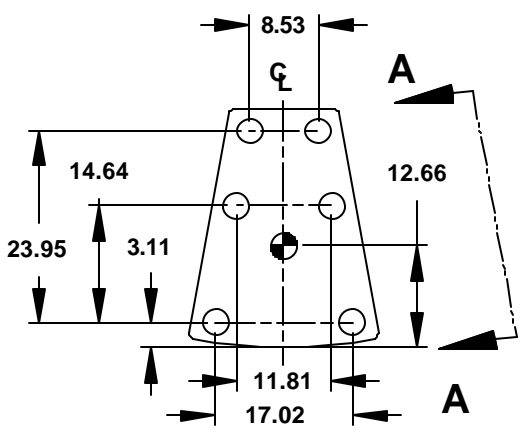

TOP

- NOTES:**
1. SYMBOL INDICATES MOUNTING POINT CASTER PALLET
 2. SYMBOL INDICATES RUBBER FOOT.
 3. SYMBOL INDICATES FOOT CUP.
 4. SYMBOL INDICATES CENTER OF BALANCE.
 5. WEIGHT APPROX. 156 LBS.
 6. SHIPPING WEIGHT APPROX. 172 LBS.

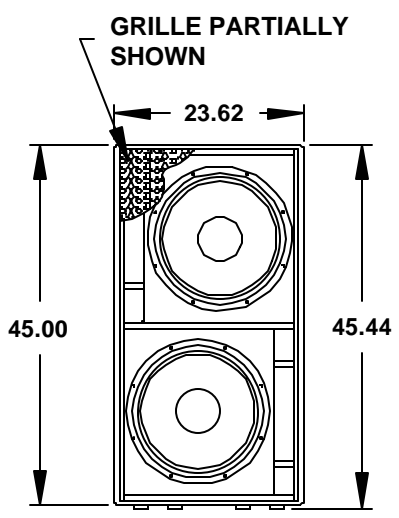

FRONT

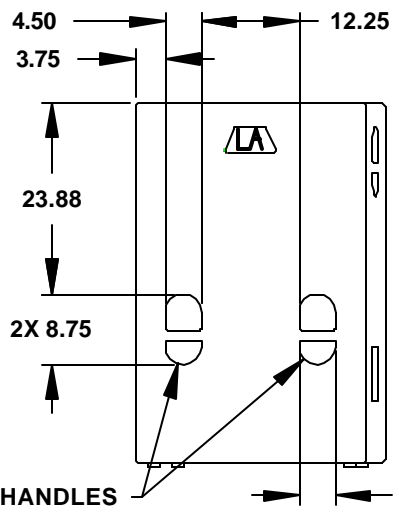

VIEW A-A
DIMENSIONS APPLY TO BOTH SIDES

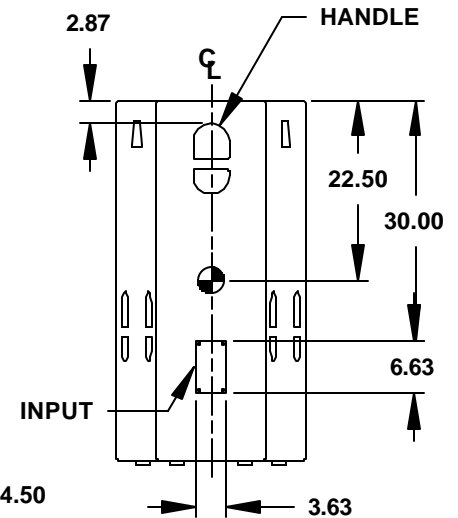

BACK

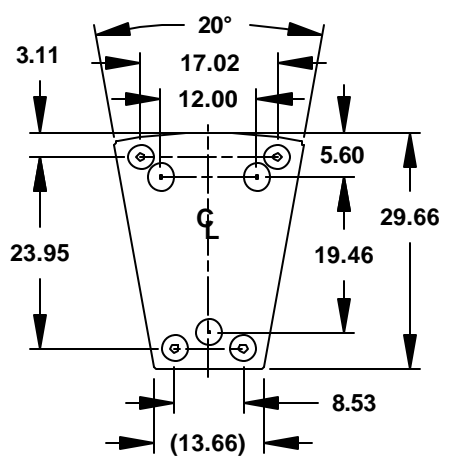

BOTTOM

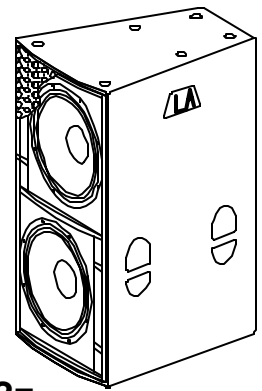

LA128z

DOCUMENT CONTROL PER SPECIFICATION 4.5.201

THIRD ANGLE PROJECTION

THIS DRAWING IS THE PROPERTY OF EAW AND SHALL NOT BE COPIED, REPRODUCED, OR USED AS THE BASIS FOR MANUFACTURE OR SALE OF APPARATUS WITHOUT WRITTEN AUTHORIZATION. DO NOT SCALE DRAWING.

UNLESS OTHERWISE SPECIFIED: ALL DIMENSIONS ARE IN INCHES

TOLERANCE IN INCHES
.XX ± .13
ANGLES ± 1°

(XXX) = REF DIMS
NO TOLERANCE IMPLIED

T.S.C. = THEORETICAL SHARP CORNER

DIMENSIONS ACROSS CENTERLINES TO BE SYMMETRICAL

STATUS: PRODUCTION	
APPROVALS	DATE
DRAWN: SS	12/18/00
CHECKED: KFH	1/16/01
DES ENG: ZC	1/19/01
MFG ENG: MD	1/19/01

EAW EASTERN ACOUSTIC WORKS
ONE MAIN STREET
WHITINSVILLE, MA 01588 USA

TITLE: CABINET/FINISHED/BLACK/
LA128z
[MECHANICAL SPECIFICATION]

A SHEET 1 OF 1 SCALE: 1 TO 24

DRAWING NUMBER: 509109 REVISION: A