

NOTES:

1. CONSTRUCT WITH EXTERIOR GRADE BALTIC BIRCH PLYWOOD. USE 3/4" PARTICLE BOARD FOR ANY INTERNAL BRACING. ASSEMBLE USING ADHESIVE 830052. PLAIN STEEL HARDWARE COMPONENTS MAY BE USED. SEE EAW MATERIAL SPECIFICATION 480500.
2. ROUT ALL OUTSIDE EDGES TO R .50.
3. ROUT INSIDE EDGES OF FRONT OF CABINET TO R .12.
4. THIS DOCUMENT DEFINES CHANGES REQUIRED FROM STANDARD PRODUCTION CABINET 0001137 (A) KF300z. CHANGE AS FOLLOWS: REPLACE FLYTRACK ON TOP & BOTTOM WITH PI ANGLES. NO HANDLES ON SIDES. NO STAND MOUNT ON BOTTOM.
5. CABINET USES LID #0001361.

REV	DESCRIPTION	APVD/DATE
A	NEW ISSUE PER DSR 02-977 MFL 8/13/02	RS 8/13/02

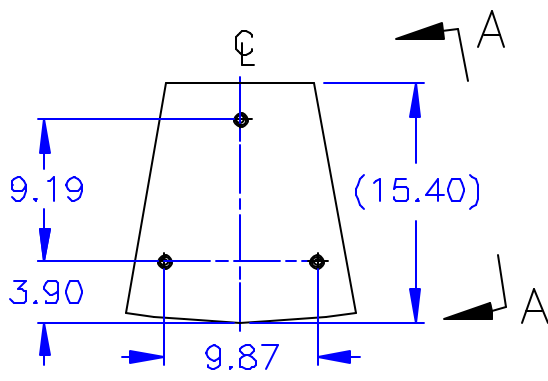

TOP/BOTTOM

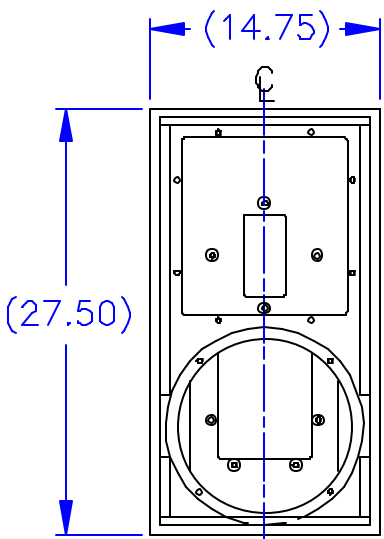

FRONT

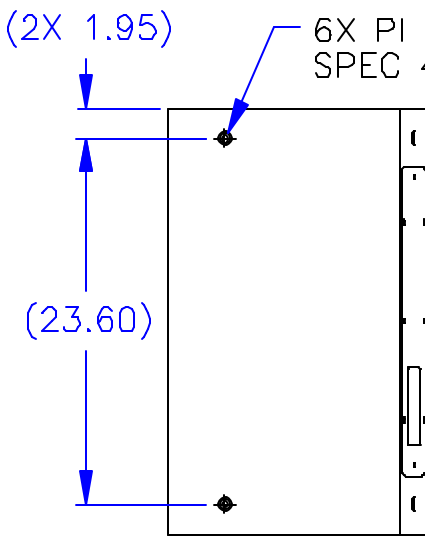

VIEW A-A

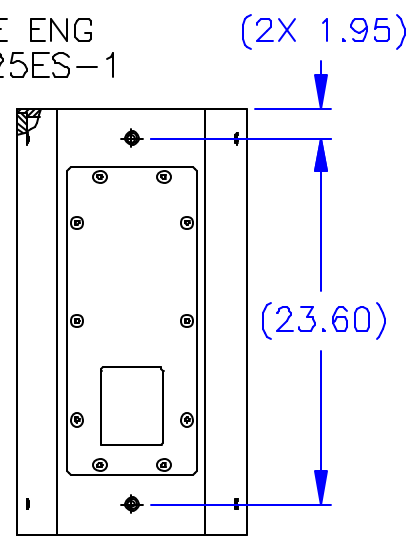

BACK

DIMENSIONS APPLY TO BOTH SIDES DOCUMENT CONTROL PER SPECIFICATION 4.5.201

THIRD ANGLE PROJECTION

THIS DRAWING IS THE PROPERTY OF EAW AND SHALL NOT BE COPIED, REPRODUCED, OR USED AS THE BASIS FOR MANUFACTURE OR SALE OF APPARATUS WITHOUT WRITTEN AUTHORIZATION. DO NOT SCALE DRAWING.

UNLESS OTHERWISE SPECIFIED: ALL DIMENSIONS ARE IN INCHES

TOLERANCE IN INCHES
 .X ± .1 .XX ± .03 .XXX ± .010
 FRACTIONS ± 1/32
 ANGLES ± 1/2°

(X.XX) = REF DIMS
 NO TOLERANCE IMPLIED

T.S.C.=THEORETICAL SHARP CORNER

DIMENSIONS ACROSS CENTERLINES TO BE SYMMETRICAL

STATUS: BTO	
APPROVALS	DATE
DRAWN: MFL	8/13/02
CHECKED: RS	8/13/02
DES ENG: NDB	8/13/02
MFG ENG: DBD	8/13/02

EAW EASTERN ACOUSTICWORKS
 ONE MAIN STREET
 WHITINSVILLE, MA 01588 USA

TITLE: CABINET/UNPAINTED-KF300zP
 [MANUFACTURING SPECIFICATION]

A SHEET 1 OF 1 SCALE: 1 TO 12

DRAWING NUMBER: 0004454 REVISION: A