

DMXPlayback Mk2



GENERAL INFORMATION

The DMXPlayback Mk2 is an entry level show recorder with a lot of robust features, making it ideal for many lower budget or just straightforward lighting control applications. With this unit you can record and edit a light show using the free Show Editor software, then let the unit play back the show for as long as you like. It is perfect for unattended light shows or demonstrations that run continuously, or to play back snapshots that are static. Store up to 12 shows and add a Remote unit to choose between them.

APPLICATIONS

- ARCHITECTURAL
- TRADE SHOW
- RESTAURANTS, RETAIL STORES

FEATURES

- Rack mountable with optional kits
- Control up to 512 channels
- Record up to 12 shows
- RS232 Serial Port for configuration and interconnection with other control systems
- DMX input port -- User may take snapshots of looks programmed on an external console then store them for inclusion anywhere in any of the 12 shows, or even on hard disk for later retrieval
- DMX output port for playback
- LCD screen provides useful status info
- DMX Start Frame, a special "Power Up" look available for striking lamps or other needs
- Shows can be triggered by switch closure, power up, RS232 command, and more

ACCESSORIES

- DMXPlayback Remote (not included)
- Rack Mounting Ears for a single unit (1RU) (not included)
- Rack Mounting plate for 2 units (2RU) (not included)
- 3-pin to 5-pin Adapters (not included)
- USB to RS232 Smart Adapter (not included)

ORDERING INFORMATION

Part Number	Description
#70014	DMXPlayback Mk2

OPTIONS

Part Number	Description
#70029	3-pin to 5-pin Adapters
#70006	2U 19" Rack Mount Kit
#70018	1U 19" Rack Mount Kit
#70013	USB to RS232 adapter
#70027	DMXPlayback Remote

SPARE PARTS

Part Number	Description
#79104	Universal Power Supply

GENERAL SPECIFICATIONS

Power Requirements	110v-240v AC
Weight	1.65 lbs / 0.75 kg
Shipped Weight	3.19 lbs / 1.45 kg
Width:	7.53" / 191mm
Height	1.75" / 44.45mm
Depth	4.14" / 105mm
Rack	1RU high x ½ RU wide
Operating Environment	0°-50°C in non-condensing environment

FUNCTIONAL SPECIFICATIONS

- Record up to 12 shows which can contain all or some of the channels patched
- Up to 65,535 Scenes total and per show
- Actual number of cues that will fit in storage determined by total number of channels used. For 512 channel show, 12 shows can each store 80 cues before compression is applied. (Optional compression increases storage efficiency but interferes with RS232 commands to Load or Jump to scene)
- RS232 port allows interconnection with Enttec DMXPlaybackRemote for seamless manual triggering of 12 shows, and Showeditor software,
- Supports a wide range of RS232 commands allowing integration with other control systems. See Enttec RS232 Protocol for details
- LCD display provides status information on current show and fade position..
- Includes ShowEditor software (required to store shows) which is compatible with Windows 95/98/ME/NT/2000/XP
- ShowEditor can take snapshots of DMX input or create new scenes from scratch, including support for moving lights with its Intensity, Color, Beam and Focus Inspector
- External power supply for 9-12V DC, or use AC power input on 2.1mm DC Jack
- CE, FCC certified

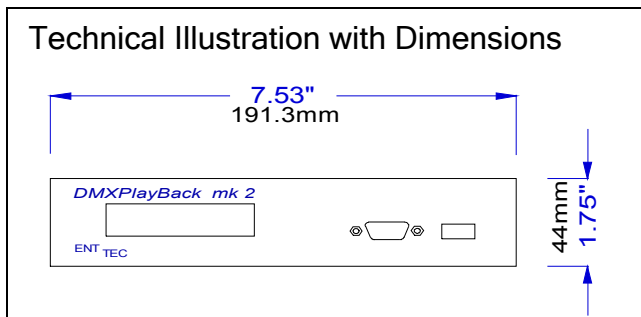

Wiring Diagrams (Riser)

DMXPlayback Mk2 with ShowEditor
used to create and store scenes

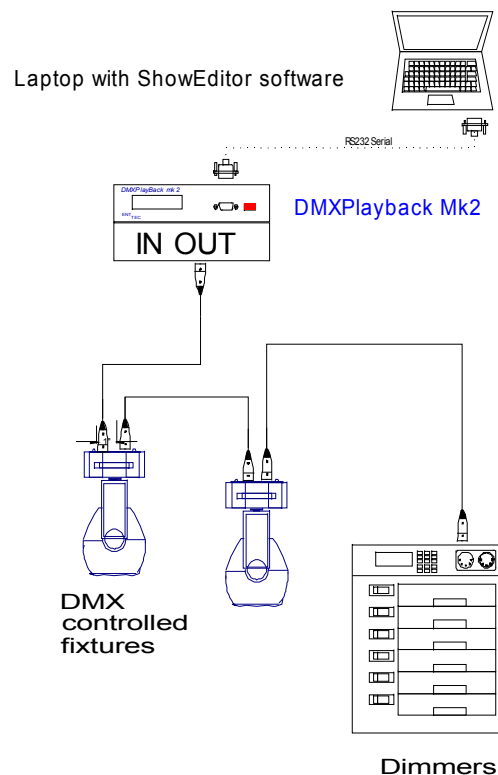

See additional Risers, Plates 70014-1 through 70014-3 as well.

ENTTEC Main HQ
P.O. Box 282
Kew, Vic 3101
Australia
+61 3 9819 2433 Tel
+61 3 9819 2733 Fax

ENTTEC USA
SHIPPING AND BILLING
500-A Bynum Road
Forest Hill, MD

ENTTEC USA
SALES AND INFO
sales@enttec.com
888 454-5922 Tel.
888 454-5922 Fax