

REV	DESCRIPTION	APVD/DATE
A	ORACLE REVISION CONVERSION DRAWING WAS REVISION 0 UPDATED PER ECO#5151 JH 7/25/01	SS 7/31/01
B	MOVED INPUT FROM TOP TO BACK OF CAB SEE SECTION D-D PER ECO 5509 SS 4/30/02	PSN 5/1/02

NOTES:

1. SYMBOL INDICATES MOUNTING POINT, 3/8-16 THREADED HOLE (PI ANGLE).
2. SYMBOL INDICATES MOUNTING POINT, 3/8-16 THREADED HOLE (NUT PLATE)
4. SYMBOL INDICATES CENTER OF BALANCE.
5. WEIGHT APPROX. 130 LBS.
6. SHIPPING WEIGHT APPROX. 143 LBS

DC1 LF LEFT

TOP
DIMENSIONS APPLY TO
TOP AND BOTTOM

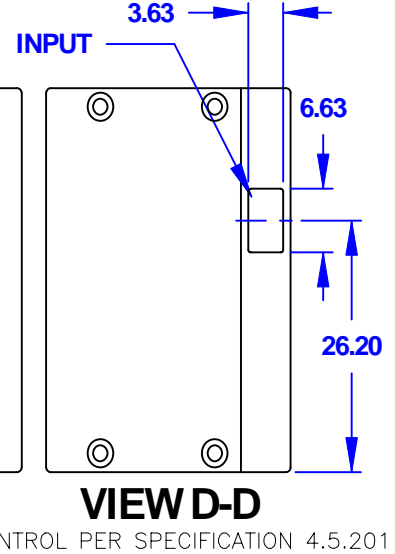
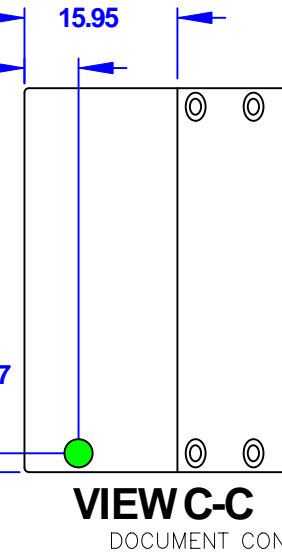
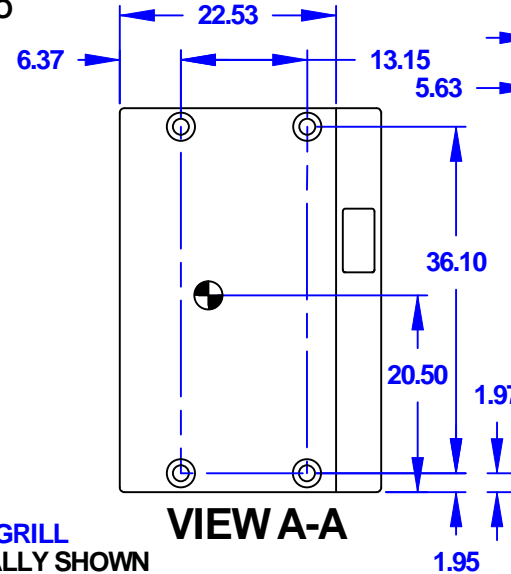
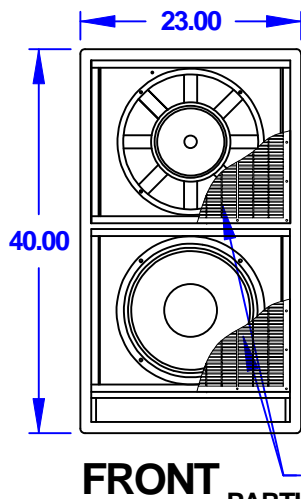
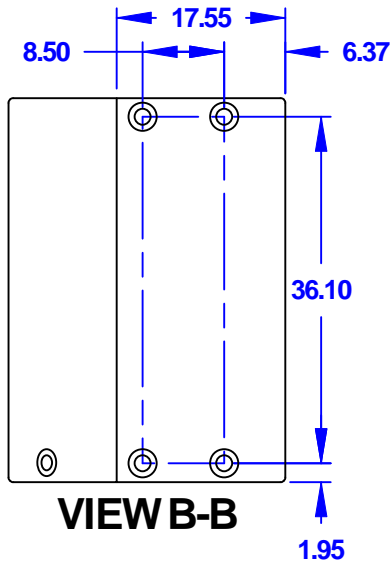

DOCUMENT CONTROL PER SPECIFICATION 4.5.201

<p>THIRD ANGLE PROJECTION</p>	<p>UNLESS OTHERWISE SPECIFIED: ALL DIMENSIONS ARE IN INCHES TOLERANCE IN INCHES .XX ± .13 ANGLES ± 1°</p> <p>(X.XX) = REF DIMS NO TOLERANCE IMPLIED</p> <p>T.S.C.=THEORETICAL SHARP CORNER</p> <p>DIMENSIONS ACROSS CENTERLINES TO BE SYMMETRICAL</p>	<p>STATUS: PRODUCTION</p>		<p>EA EASTERN ACOUSTIC WORKS ONE MAIN STREET WHITINSVILLE, MA 01588 USA</p>
		<p>APPROVALS</p> <p>DRAWN: MFL 7/23/99</p> <p>CHECKED: KFH 8/12/99</p> <p>DES ENG: ZC 8/19/99</p> <p>MFG ENG: CAC 8/23/99</p>	<p>DATE</p>	
<p>THIS DRAWING IS THE PROPERTY OF EAW AND SHALL NOT BE COPIED, REPRODUCED, OR USED AS THE BASIS FOR MANUFACTURE OR SALE OF APPARATUS WITHOUT WRITTEN AUTHORIZATION. DO NOT SCALE DRAWING.</p>		<p>A SHEET 1 OF 1 SCALE: 1 TO 20</p>		<p>DRAWING NUMBER: 510845 REVISION: B</p>