



ne800
ne800.10
ne800.70
ne800.25

ne1600
ne1600.10
ne1600.70

ne2400
ne2400.10

**Network Enabled
Two Channel Power Amplifiers**

Operating Manual

ASHLY AUDIO INC.

847 Holt Road Webster, NY 14580-9103 Phone: (585) 872-0010

Toll-Free: (800) 828-6308 Fax: (585) 872-0739 www.ashly.com

Table Of Contents

1 INTRODUCTION	3
2 UNPACKING	3
3 THE NE TWO CHANNEL AMP SERIES	3
ne800 Models	3
ne1600 and ne2400 Models	4
Amplifier Options Overview	4
Protection	5
Physical Description	5
Front Panel Features	5
Rear Panel Features	6
Installation Requirements	6
4 REMOTE AMPLIFIER CONTROL	7
On/Off Remote Standby	7
Remote Level Control (WR-1)	7
5 PROTEA^{ne} SOFTWARE	8
Overview	8
Amplifier Control Surface	8
The DSP Window	9
6 SPECIFICATIONS	10
7 WARRANTY INFORMATION	12



TO REDUCE THE RISK OF ELECTRIC SHOCK, DO NOT REMOVE COVER. NO USER SERVICEABLE PARTS INSIDE. REFER SERVICING TO QUALIFIED SERVICE PERSONNEL.

TO REDUCE THE RISK OF FIRE OR ELECTRICAL SHOCK, DO NOT EXPOSE THIS APPIANCE TO RAIN OR MOISTURE.

TO REDUCE THE RISK OF FIRE, REPLACE ONLY WITH SAME TYPE FUSE. REFER REPLACEMENT TO QUALIFIED SERVICE PERSONNEL.

WARNING:
THIS APPARATUS MUST BE EARTHED

1. INTRODUCTION

Thank you for your purchase of this **NE** (network enabled) two channel power amplifier. **Ashly NE** power amplifiers combine lightweight, state of the art, high efficiency switching technology with integrated Ethernet control, and use optional modular expansion cards to provide comprehensive internal DSP processing, AES/EBU input, and networked digital audio (CobraNet) input. Please read the entire manual to fully understand the features and capabilities of this product.

About Ashly

Ashly Audio was founded in 1974 by a group of recording engineers, concert sound professionals, and electronics designers. The first products were elaborate custom consoles for friends and associates, but business quickly spread to new clients and the business grew. The philosophy we established from the very beginning holds true today: to offer only the highest quality audio tools at an affordable cost to the professional user – ensuring reliability and long life. More than thirty years later, Ashly remains committed to these principles.

Ashly’s exclusive Five Year, Worry Free Warranty remains one of the most liberal policies available on any commercial grade product. The warranty covers every product with the Ashly brand name, and is offered at no extra cost to you, our customer.

FCC Compliance

This device complies with part 15 of the FCC Rules. Operation is subject to the following two conditions:

1. This device may not cause harmful interference
2. This device must accept any interference received, including interference that may cause undesired operation.

2. UNPACKING

As a part of our system of quality control, every Ashly product is carefully inspected before leaving the factory to ensure flawless appearance. After unpacking, please inspect for any physical damage. Save the shipping carton and all packing materials, as they were carefully designed to minimize the possibility of transportation damage should the unit again require packing and shipping. In the event that damage has occurred, immediately notify your dealer so that a written claim to cover the damages can be initiated.

The right to any claim against a public carrier can be forfeited if the carrier is not notified promptly and if the shipping carton and packing materials are not available for inspection by the carrier. Save all packing materials until the claim has been settled.

3. THE NE TWO CHANNEL AMP SERIES

ne800 Models	ne800			ne800.10			ne800.70			ne800.25		
	RATED WATTS	RATED VOLTS	RATED LOAD Ω	RATED WATTS	RATED VOLTS	RATED LOAD Ω	RATED WATTS	RATED VOLTS	RATED LOAD Ω	RATED WATTS	RATED VOLTS	RATED LOAD Ω
Stereo Mode Both Channels Driven 20Hz - 20KHz 1% THD				400	100	25	400	70	12.3	400	25	1.6
	225	42.4	8	128*	32*	8*	261*	45.7*	8*	78	25	8
	400	40	4	64*	16*	4*	131*	22.9*	4*	156	25	4
	200*	20*	2*	32*	8*	2*	65*	11.4*	2*	313	25	2
Bridged Mode	800	80	8	800	200	50	800	140	24.5	800	50	3.1

* Values indicated by an asterisk are intended as guidelines only. Amplifier is not rated for this load impedance and may self-protect depending on load and program.

ne1600 Models	ne1600			ne1600.10			ne1600.70		
	RATED WATTS	RATED VOLTS	RATED LOAD Ω	RATED WATTS	RATED VOLTS	RATED LOAD Ω	RATED WATTS	RATED VOLTS	RATED LOAD Ω
Stereo Mode Both Channels Driven 20Hz - 20KHz 1% THD				800	100	12.5	800	70	6.1
	450	60	8	512*	64*	8*	613	70	8
	800	56.6	4	256*	32*	4*	522*	45.7*	4*
	400*	28.3*	2*	128*	16*	2*	261*	22.9*	2*
Bridged Mode	1600	113	8	1600	200	25	1600	140	12.3

ne2400 Models	ne2400			ne2400.10		
	RATED WATTS	RATED VOLTS	RATED LOAD Ω	RATED WATTS	RATED VOLTS	RATED LOAD Ω
Stereo Mode Both Channels Driven 20Hz - 20KHz 1% THD				1200	100	8.3
	700	74.8	8	1152*	96*	8*
	1200	69.3	4	576*	48*	4*
	600*	34.6*	2*	288*	24*	2*
Bridged Mode	2400	139	8	2400	200	16.7

* Values indicated by an asterisk are intended as guidelines only. Amplifier is not rated for this load impedance and may self-protect depending on load and program.

All NE two channel power amplifiers come standard with XLR and Euroblock input connectors, and Speakon/Euroblock output connectors. All models include balanced analog inputs, bridge mono mode, an 80Hz hi-pass filter, input sensitivity switch, full Ethernet control using Protea^{ne} software, remote standby for power up, and DC remote level control using an Ashly WR-1 or equivalent.

All NE two channel amplifiers also include Analog Aux Outputs on XLR and Euroblock connectors. The Aux Outputs are buffered signals taken just before the power amplifier driver stage. If there is no DSP capability installed in the amplifier, the Aux Outputs are simply a buffered signal matching the inputs. If the amplifier has DSP installed however, each Aux Output can be independently configured, in addition to the two main amplifier channels, with its own DSP processing and any input source, including AES/EBU or CobraNet (if installed) to drive other power amplifiers.

Additional options are available for the NE two channel power amplifiers including the following:

1) Internal DSP Processing - With this factory installed option, and using Protea^{ne} (network enabled) software, each amplifier input channel can be configured with pluggable DSP blocks to have its own dynamics control, gain functions, graphic and/or parametric EQ, Hi-pass/Lo-pass filters, time delay, metering, and test signal generator. A mixer section with assignable routing allows any input to drive any or all amplifier outputs. Outputs have the same DSP functions as inputs, with the addition of a fast, automated crossover setup. Both inputs and outputs can copy/paste their settings to other channels, or can link with one or more other channels to track their settings.

Presets can be used to store and retrieve global parameters of an amplifier’s control surface and DSP section from a file. In addition, Sub Presets allow for a collection of individual DSP function parameters within and across both channels of an amplifier to be stored and recalled as a set, affecting only those parameters which have been tagged. Up to 35 presets/subpresets can be stored within the amplifier, and can be recalled in real time via Ethernet from a computer using Protea^{ne} software.

2) AES/EBU Input - Using an optional input card, NE two channel amplifiers can accept AES/EBU digital inputs. This protocol allows 2 channels of digital audio to be transmitted over a single cable, thus maintaining a completely digital signal path until just before the power amplification stage. 48kHz & 96kHz data rates are supported.

3) Network Digital Audio (CobraNet) - This option allows the NE two channel amplifier to be part of a networked audio distribution system. CobraNet is a technology developed and supported by Cirrus Logic (www.cirrus.com). It is a combination of software, hardware and network protocol which allows distribution of multiple channels of real-time, high quality digital audio over a standard Ethernet Network. For detailed information about CobraNet or its implementation visit www.cobranet.info.

Protection

Ashly NE two channel power amplifiers come standard with several protection circuits:

Over Current Protection - Is controlled in the output stage.

Thermal Protection - When the internal temperature is below 40°C the fan runs at its slowest speed. Above 40°C the speed is increased until it reaches its maximum value. If the temperature exceeds 100°C, the input on that channel is reduced. If the temperature exceeds 110°C, the power supply is switched off.

Mains Protections – protection within the power supply includes: Inrush Current Limitation during power up, Mains Over Voltage Detection, and internal Mains Fuse Protection. To protect the Mains fuse against AC overcurrent due to excessive audio output current, there is a protection scheme controlled in **Protea^{ne}** software and indicated on the amplifier front panel which reduces audio output level until the overcurrent condition is no longer present.

Physical Description

Each model in the NE two channel series is 2RU, and weighs 22 pounds (10kg) or less. The model number is indicated in the lower left corner of the front panel.

Amplifier Front Panel

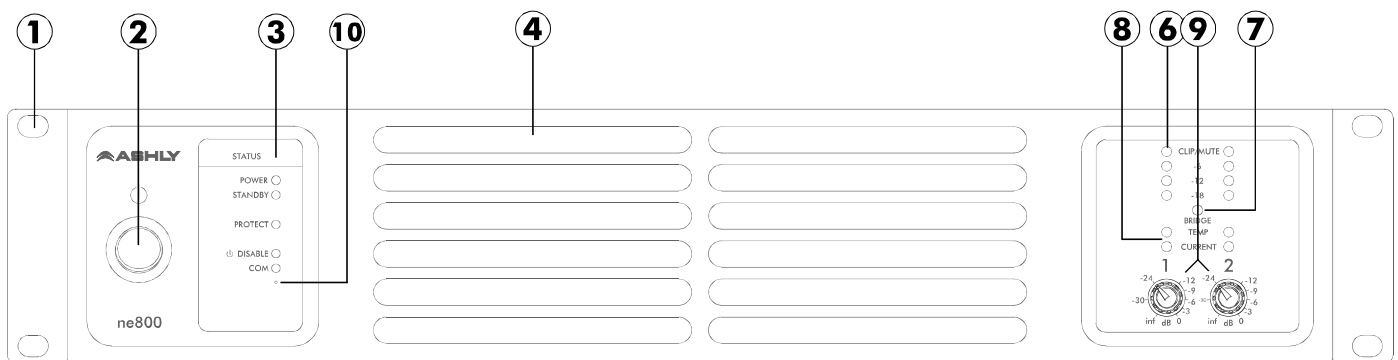

- 1. Mounting Holes** – For rack mounting.
- 2. Power Switch** – Switches the unit on or off. *Note: The power switch can be disabled from **Protea^{ne}** Software.*
- 3. Status LEDs** – Indicate status of: Power, Standby, Protect, Power Switch Disable, and Com (Ethernet activity).
- 4. Air Inflow Vents** – Cool air enters here.
- 6. Signal LEDs** – The lowest LED will begin to light when the output voltage reaches -18dBu below rated output. The Clip LEDs will begin to flash when output voltage is 1/2 Volt below the output power supply voltage.
- 7. Bridge** – This LED indicates that the two channels are selected to BRIDGE mode from the back panel switch, and that only channel 1 level control is active.
- 8. Temp and Current LEDs** – The Temp LED indicates that the amplifier has reached an excessively high operating temperature. The Current LED confirms that the amplifier output is delivered to a speaker load.
- 9. Channel Attenuators** – These control the input signal level to the amp, and can be disabled from software.
- 10. Factory Reset** – To reset all internal configurations (including passwords) back to their original factory settings, press and hold this recessed front panel tact switch during power up until all channel LEDs are lit. Upon reset completion, the LEDs will turn off and the amp will be in normal operating mode.

Amplifier Rear Panel

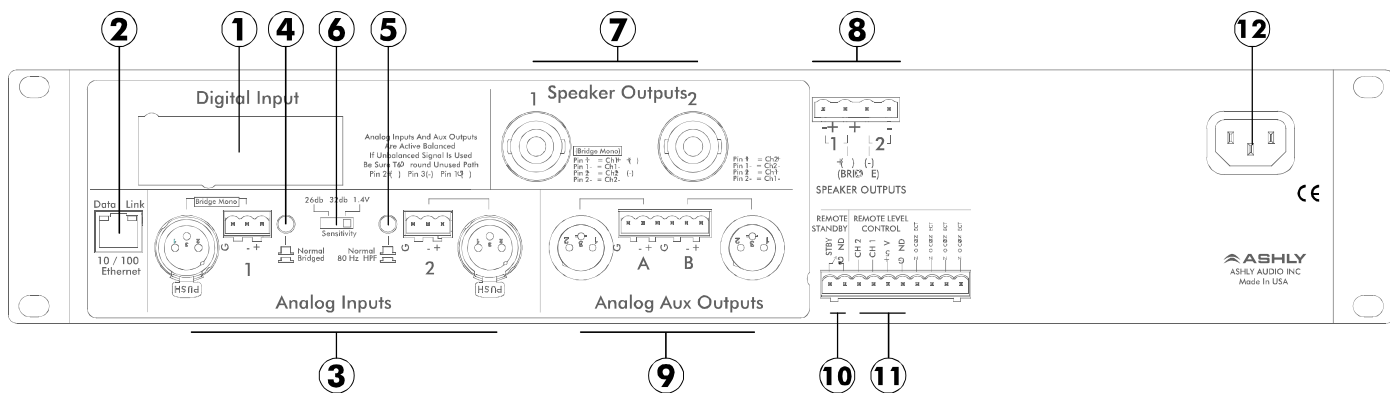

1. **Optional CobraNet CNM-2 Card or AES/EBU Input Slot** – Installation of an optional CobraNet CNM-2 card option allows this amplifier to be part of a CobraNet audio network. Installation of the AES/EBU input option in this slot allows for digital audio input in the AES/EBU format.
2. **Ethernet Port** - This offers 10/100 Ethernet control and monitoring of amplifier functions using **Protea^{ne}** software.
3. **Analog Inputs** - XLR inputs are pin 2 (+), pin 3 (-), and pin 1 (G). Euroblock inputs are wired in parallel to the XLRs. If an unbalanced (single ended) input is used, be sure to ground the unused input pin.
4. **Normal/Bridge Switch** - This switches the amplifier to Bridge Mode.
5. **Normal/80 Hz HPF** - This switch enables a second order High-Pass filter set to 80Hz on both inputs.
6. **Input Sensitivity Switch** - This switch selects the input sensitivity for both channels to 26dB, 32dB, or 1.4V.
7. **Speakon Speaker Connectors** - Used to connect the speakers.
8. **Euroblock Speaker Connectors** - This connector is wired in parallel to the Speakon speaker outputs.
9. **Analog Aux Outputs** - Used to drive additional amplifiers.
10. **Remote Standby** - Connect these two contact closure pins to remotely place the amp in standby.
11. **Remote Level Control** - These pins can be wired to remote potentiometers such as the Ashly WR-1 for level control of individual channels.
12. **AC Inlet** - Used for the detachable AC cord.

WARNING: Do not remove or lift the mains connector ground.

Installation

Before connecting to mains power, make sure that the switches and wiring are all set to the configuration needed for your particular application. Failure to do so could result in damage to the unit or other components in your system. **CAUTION:** When mounting or connecting the amplifier, always disconnect it from the mains. Use four screws and washers when mounting the amplifier to the front rack rails. Rear support is also recommended, especially for mobile or touring use. To reduce the risk of fire or electric shock, do not expose this apparatus to rain or moisture.

Requirements

Ashly NE two channel amplifiers have specific physical, electrical and signal requirements for proper operation. These requirements will vary depending on your specific application, setup, and the settings on the amplifier. When setting up and testing your system, please take special care to double check all connections and settings. Please refer to the specifications section of this manual for specific input, output and other figures.

4. REMOTE AMPLIFIER CONTROL

ON/OFF/Remote Standby

The NE two channel amplifiers have three possible states, OFF, ON, and STANDBY, each with a status LED on the front panel. Control for these three states is managed by the following:

1) **Power Switch** - When the power switch is turned off the amplifier is completely off, UNLESS the power switch has been disabled from within **Protea^{ne}** software, in which case the power switch on the amplifier has no effect at all. If the power switch has been disabled from software, the front panel DISABLE LED will be lit. *Even if the AC power is removed, the amplifier's internal memory will maintain the <power switch disabled> status until changed again from Protea^{ne} software. Performing a factory reset will clear and restore all internal amplifier memory to factory settings.*

2) **Remote Standby Contact Closure** - When these two euroblock pins on the back of the amplifier (see amplifier rear panel illustration #10) are wired to a switch and *connected*, the amp will go into Standby mode, whereby the amp is active but not fully powered up. For Remote Standby to work, the power switch must be turned on OR be disabled through **Protea^{ne}** software.

3) **Protea^{ne} Software On/Standby** - On/Standby in the **Protea^{ne}** two channel amp software functions the same as the hardware based Remote Standby Contact Closure on the back panel. Clicking on STANDBY places the amp in standby mode. The On/Standby in software does not override the hardware Remote Standby, they both remain active.

4) **Protea^{ne} Software Power Switch Enable/Disable** - Use this software feature to disallow use of the front panel power switch. If the power switch has been disabled from software, the front panel DISABLE LED will light on the amplifier. The power switch will remain inactive until enabled again from software, even if the amp is removed from power.



Protea^{ne} Software Remote Power Control

WR-1 Remote Level Control

Either amplifier channel can have remote attenuation by using a potentiometer assembly such as the Ashly WR-1 and four conductor wire. The WR-1 is a dual potentiometer remote volume control designed to fit in a standard electrical wall box. Each volume control is connected to a terminal block on the WR-1 circuit board, which in turn must be wired to the amplifier back panel euroblock connector labeled "Remote Level Control" as shown. CV-1 = Control Voltage for Channel 1, etc. There is no wire length limitation for Remote Level Control. *Do not connect the WR-1 remote level control ground to any other external grounds.*

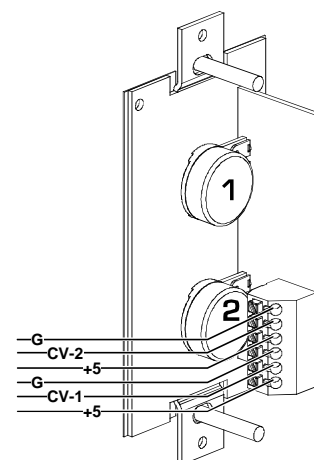

Ashly WR-1 Remote Level Control

5. PROTEA^{ne} SOFTWARE

Protea^{ne} software offers a comprehensive suite of tools for controlling Ashly NE amplifiers as well as other Ashly products. The standard NE two channel amplifiers allow for Ethernet control and monitoring of power functions, level, mute, polarity, and live speaker load analysis. With the DSP option installed, software control and monitoring of major audio functions can be custom configured on a per channel basis, as well as through linked channels. *More in-depth discussion of software features can be found in the Protea^{ne} software online help.*

The base amplifier comes with software provisions for an audio control surface, password protected security functions, and network property management. Furthermore, Link Group Configuration and Power On Delay are set up under the Device Options menu tab. In addition, provisions for implementing DSP modes, AES/EBU Inputs, and CobraNet inputs are made available, presuming the necessary optional hardware has been installed in the amplifier. Protea^{ne} software will auto-detect the installed amplifier hardware options and display the resultant menu items as soon as it recognizes the amplifier on the network.

Link Group Configuration - Linking allows the controls for multiple signal processing function “blocks” to track each other. For example - if two graphic equalizer blocks are “linked”, any change made to a control within either of the equalizers will result in an identical change to the other. Blocks may be linked within a Protea^{ne} device, or across multiple devices (assuming that devices are networked). Linking of multiple devices is managed through LINK GROUPS.

Each NE two channel amplifier will support up to 16 Link Groups. DSP function blocks may be assigned to these groups through Protea^{ne} Software. Once assigned to a group all LIKE functions within the group will track parameter changes. However more than one function type may be assigned to a group. Each LINK GROUP may be assigned a name by the user, and also be assigned a color for easy identification. For further details about linking, see the online help in Protea^{ne} Software.

Preset Options - The Preset Options tab in the main amplifier window allows amplifier setups to be saved to and recalled from the amplifier as well as a computer. Presets are a snapshot of all current settings on a given amplifier.

Sub Presets - Sub Presets are user defined groups of DSP functions within one channel or across multiple channels. Sub Presets allow the end user to instantly recall a pre-determined set of DSP parameters to quickly address changing environmental conditions, without the risk of making undesirable or irrecoverable system changes.

The Amplifier Control Surface (*see image next page*)

This is the main user interface for the NE two channel amplifier. Key features of this window include:

1) Channel/Offset Link Group Faders - The level control provides up to 40dB of analog input attenuation. More than 40dB of cumulative attenuation causes the channel to mute. If a channel has been assigned to an offset link group, a colored triangular marker appears on the left side of the fader graticule for secondary level control of all channels in that group. The main level control faders can not be linked to a group.

2) Mute button - This mutes the input channel.

3) Polarity button - This inverts the phase of the input channel.

4) Offset link group - Up to eight groups are available for the purpose of linking similar function parameters across multiple channels. In addition to the control surface secondary level control (not the main fader), most DSP functions have a link group check box in their work window to assign a specific parameter to one of the eight link groups if desired. Link groups can be renamed by clicking on any group name and entering the new name then pressing <enter> on the keyboard.

5) Attenuators - These two dials indicate the physical position of hardware controls on either the amp front panel or the remote level control (if present). Note that these will display the position of attenuators even when DISABLED in software.

6) Total Attenuation - This indicates the total amount of attenuation being applied to the channel. This is the sum of the following attenuators: main fader, offset link group attenuation, front panel and remote attenuators (if enabled).

7) Meters - Input and Output meters display the real time activity per channel, in dB below rated output. Also, the amplifier's operating temperature and output current are shown. Output current shows that the amplifier channel is actually delivering output to a connected speaker load.

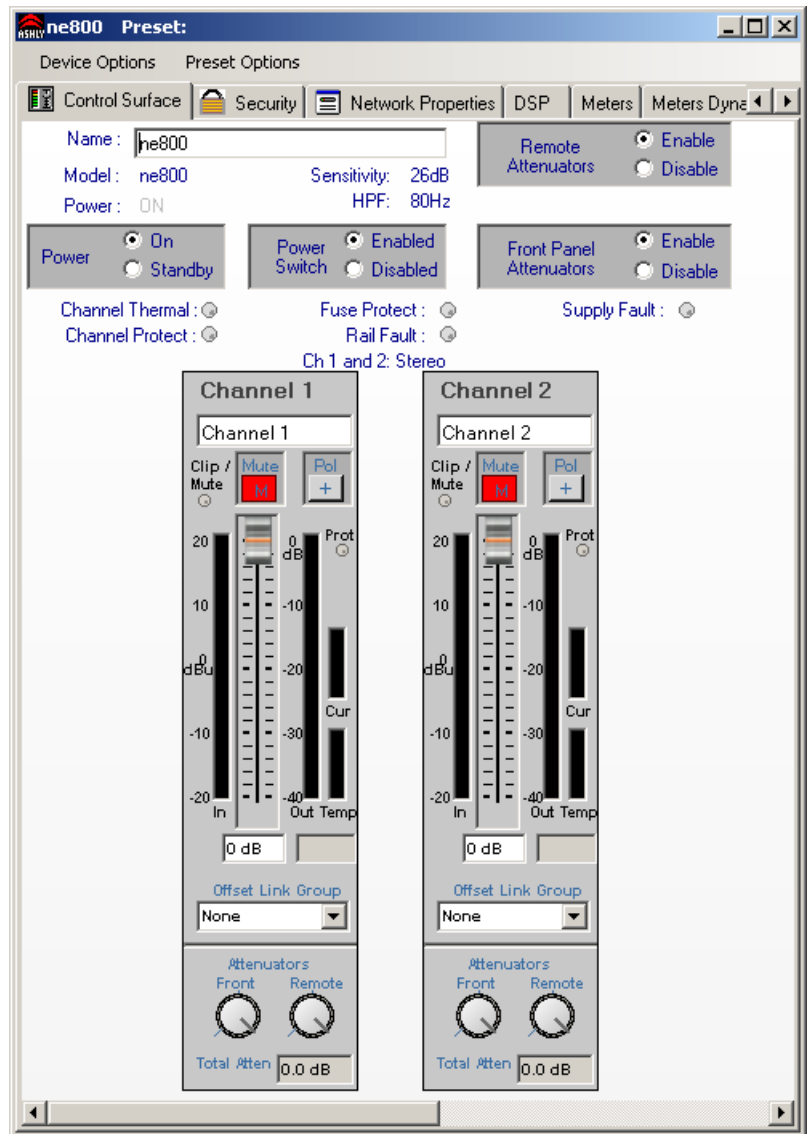

Protea^{ne} Two-Channel Amplifier Control Surface

The DSP Window

Extensive online help information is available for all DSP blocks. Look in the Protea^{ne} Software Help Menu/Contents and Index/Contents/Protea NE Products/NE Amplifiers/DSP Control for details of all DSP functions. The key features include:

- 1) Input Channel Number - Right click on this to bring up Clear, Copy, Link, and Sub Preset functions for that input channel.
- 2) Input Channel Name - The user can name each input channel.
- 3) Input Mute Button - Mutes the input.
- 4) Pluggable Input DSP Tools - Six boxes are available for custom configuration of pluggable DSP processing blocks. Available DSP blocks include Dynamics controls, Gain and Remote Gain functions, Graphic and Parametric EQ, Crossover functions, Delay, Metering, and a Signal Generator.
- 5) Input/Output Matrix Router - Any input can be routed to any or all outputs. Click and drag from the input to output to assign routing. To delete a route, right click on the routing line and delete.

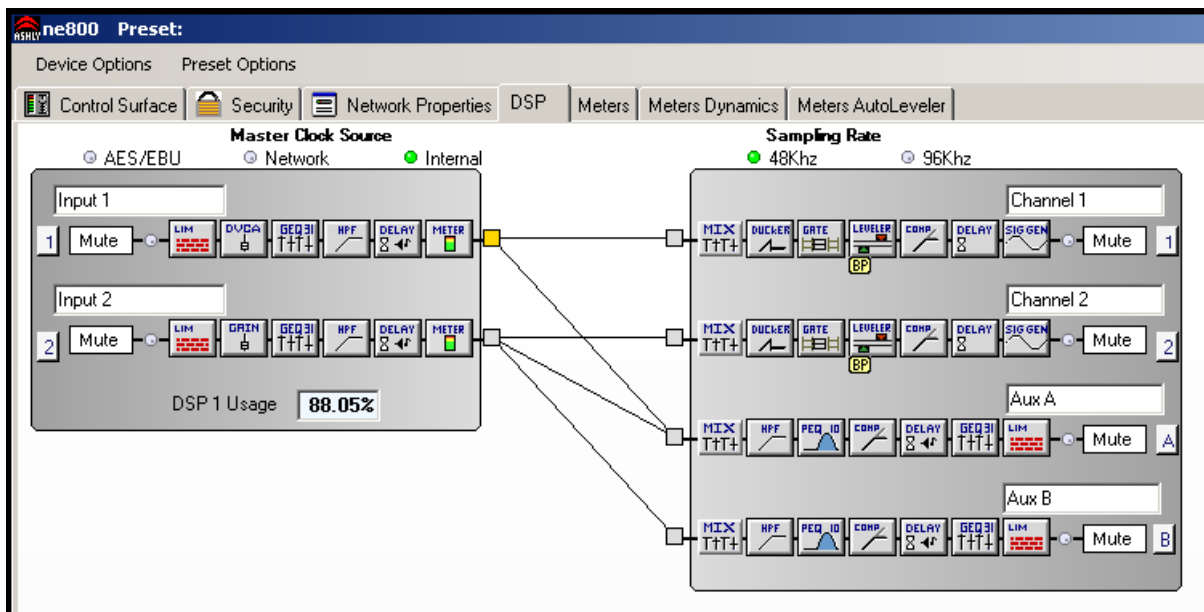

Protea^{ne} Two Channel Amplifier DSP Control Surface (DSP option must be installed)

- 6) Output Mixer - For a given amplifier output channel, all inputs that have been routed in the matrix router are mixed together here.
- 7) Pluggable Output DSP Tools - Output DSP tools are the same as those available to the inputs.
- 8) Output Mute Button - Mutes the output.
- 9) Output Channel Name - The user can name each output channel.
- 10) Output Channel Number - Right click on this to bring up Clear, Copy, Link, and Sub Preset functions for that output channel.

6. SPECIFICATIONS

GENERAL POWER AMPLIFIER SPECIFICATIONS

Power Output Per Channel

<i>Stereo Mode, Both Channels Driven</i>	ne 800	ne 1600	ne 2400
8Ω, 20Hz-20kHz 1%THD	225W	450W	700W
4Ω, 20Hz-20kHz 1%THD	400W	800W	1200W

Bridge Mode

8Ω, 20Hz-20kHz 1%THD	800W	1600W	2400W
25V (ne 800 only), 70V, and 100V models	400W	800W	1200W
20Hz-20kHz 1%THD, per channel			

Line Current Draw (both channels driven 4Ω /Ch, 120VAC Mains)

Line Current, Standby mode	200mA	165mA	200mA
Line Current, Idle (no signal)	475mA	500mA	475mA
Line Current, Typical (1/8 power pink noise)	2.81A	4.95A	6.75A
Line Current, Maximum (1/3 power sine wave)	4.93A	8.80A	12.6A

Thermal Dissipation (BTU/hr, both channels driven 4Ω /Ch)

BTU/hr, Standby mode,	40	40	40
BTU/hr, Idle (no signal)	109	109	109
BTU/hr, Typ (1/8 power pink noise)	287	447	682
BTU/hr, Max (1/3 power sine wave)	297	466	717

Signal to Noise (20Hz-20KHz, unweighted)	>107dB	>110dB	>112dB
--	--------	--------	--------

Distortion (SMPTE, typical) - 8 ohm load, 10dB below rated power: <0.5%
Distortion (THD-N, typical) - 8 ohm load, 10dB below rated power, 20Hz-20kHz: <0.5%
Frequency Response 20Hz-20kHz, +/-1dB
Damping Factor (8 ohm load, <1kHz) >250
Input Impedance 20K Ohm, balanced
Maximum Input Level +21dB

Cooling temperature dependent speed-controlled axial fan
Control Network onboard, compatible with standard 100MB Ethernet hardware
Front Panel Indicators .. per channel: Clip/Mute, -6dB, -12dB, -18dB, Temp, Current, Bridge
overall: Power, Standby, Protect, Power Switch Disable, Com
Control Surface and Amp LEDs: Level meters are dB below RATED output
Attenuators: per channel: front panel, software, offset link group, and remote

Input Connections XLR Female /Euroblock
Analog Aux Outputs XLR Male / Euroblock
Output Connections Speakon / Euroblock
Remote Standby Euroblock
Remote Level Control ... Euroblock
Amplifier Protection inrush current limitation, temperature monitoring, output over-current protection, mains fuses
Power Cable Connector 15A Edison

Dimensions 19"W x 3.5"H x 15.5"D (483 x 89 x 394mm)
Weight 21 lbs (9.53kg)
Environmental: 40-120 deg. F, (4-49 deg. C) noncondensing

DSP SPECIFICATIONS

Input: Active Balanced, 10 kohms
Max Input Level: +21 dBu

DYNAMICS

Brick Wall Limiter

Threshold: -20dBu to +20dBu
Ratio: infinite
Attack: 0.2ms/dB to 50 ms/dB
Release: 5ms/dB to 1000ms/dB

Compressor

Threshold: -20dBu to +20dBu
Ratio: 1.2:1 to infinite
Attack: 0.2 to 50ms
Release: 5ms/dB to 1000ms/dB
Detector: Peak/Average

Autoleveler

Target Level: -40dBu to +20dBu
Action: gentle, normal, aggressive,
user defined
Maximum Gain: 0dB to +22dB
Ratio: 1.2:1 to 10:1
Threshold Below Target: -30dB to 0dB
Gain Increase Rate: 5ms/dB to 1000ms/dB
Gain Decrease Rate: ... 5ms/dB to 1000ms/dB
Hold Time: 0-6 sec

Ducker

Ducking Type: high/low priority trigger,
..... filibuster, ducked program
Trigger Threshold: -80dBu to +20 dBu
Ducking Release: 5ms/dB to 1000ms/dB
Ducking Depth: 0dB to -30dB

Gate

Threshold: -80dBu to +20dBu
Range: off, 100dB to 0dB
Attack: 0.2ms/dB to 50 ms/dB
Release: 5ms/dB to 1000ms/dB

GAIN

Gain: off, -50dB to +12dB
Gain w/VCA: off, -50dB to +12dB
WR-5 Remote Gain: off, -50dB to +12dB

EQUALIZATION

31 Band Graphic

Filter Type: constant Q or proportional Q
Bandwidth: 0.499oct to 0.25oct

(DSP SPECIFICATIONS, continued)

10, 6, 4, or 2 Band Parametric

Filter Types

Parametric:

Frequency: 20-20kHz
Level: -30dB to +15dB
Q Value: 0.016oct to 4oct

Hi/Low Shelf 6/12 dB

Frequency: 20Hz-20kHz
Level: -15dB to +15dB

All Pass

Frequency 20Hz-20kHz

Variable Q HP/LP

Frequency: 20Hz-20kHz
Q Value: 3.047 to 0.267

Notch/Bandpass

Frequency: 20Hz-20kHz
Q Value: 92.436 to 0.267

CROSSOVER

4 Way, 3 Way, 2 Way Crossover

High Pass/Low Pass Filters

Filter Types:

Bessel: 12/18/24/48 dB/oct
Butterworth: 12/18/24/48 dB/oct
Linkwitz: 12/24/48 dB/oct
Frequency: off, 20Hz-20KHz

DELAY

@ 48kHz Sampling Rate

Speaker Delay: 0-21ms
Long Delay: 0-682 ms

@ 96kHz Sampling Rate

Speaker Delay: 0-10.6ms
Long Delay: 0-341 ms

Ashly Audio Inc. Limited Warranty (USA ONLY)

(Other countries please contact your respective distributor or dealer)

For units purchased in the USA, warranty service for this unit shall be provided by ASHLY AUDIO, INC. in accordance with the following warranty statement:

ASHLY AUDIO, INC. warrants to the owner of this product that it will be free from defects in workmanship and materials for a period of FIVE years from the original date of purchase. ASHLY AUDIO INC. will without charge, repair or replace at its discretion any defective product or component parts upon prepaid delivery of the product to the ASHLY AUDIO, INC. factory service department, accompanied with a proof of original date of purchase in the form of a valid sales receipt. This warranty gives you specific legal rights, and you may also have other rights, which vary from state to state.

EXCLUSIONS: This warranty does not apply in the event of misuse, neglect or as a result of unauthorized alterations or repairs made to the product. This warranty is void if the serial number is altered, defaced, or removed. ASHLY AUDIO reserves the right to make changes in design, or make additions to, or improvements upon this product, without any obligation to install the same on products previously manufactured.

TOOLS

Audio Meter

Range: -60dBu to +20dBu
Increments: 1dB
Peak Hold Indicator: ... yes

Signal Generator: pink or white noise, sine wave

Sine Wave Frequency: .. 20Hz-12kHz
Signal Level: off, -50dBu to +20dBu

CROSS POINT MIXER

Gain: Off., -50 to +12dB,
0.5dB increments with Mute

LINKING

All functions can be linked to 1 of 16 link groups

DSP PROCESSORS

Input A/D: 24 bit (Burr Brown PCM4204)
Output D/A: 24 bit (Burr Brown PCM4104)
DSP Processors: 32-bit floating point
(Sharc ADSP-21262)

Sample Rates: 48kHz, 96kHz
Propagation Delay @ 48kHz: ... 1.42 ms
Propagation Delay @ 96kHz: ... 0.71 ms

AES/EBU DIGITAL AUDIO INPUT

Type: 110 ohm transformer balanced
XLR
Sample Rates: 48kHz, 96kHz
Max Cable Length: 100 meters

Any implied warranties which may arise under the operation of state law shall be effective only for FIVE years from the original date of purchase of the product. ASHLY AUDIO, INC. shall be obligated to only correct defects in the product itself. ASHLY AUDIO, INC. is not liable for any damage or injury which may result from or be incidental to or a consequence of such defect. Some states do not allow limitations on how long an implied warranty lasts, or the exclusion, or limitation of incidental or consequential damages, so the above limitations or exclusions may not apply to you.

OBTAINING WARRANTY SERVICE:

For warranty service in the United States, please follow this procedure:

1.) Return the product to ASHLY AUDIO, INC. freight prepaid, with a written statement describing the defect and application that the product is used in. ASHLY AUDIO, INC. will examine the product and perform any necessary service, including replacement of defective parts, at no further cost to you.

2.) Ship your product to:

Ashly Audio Inc.
Attn: Service Department
847 Holt Road
Webster, NY 14580-9103

ASHLY AUDIO INC. 847 Holt Road Webster, NY 14580

Phone: (585) 872-0010 Fax: (585) 872-0739

Toll Free (800) 828-6308 www.ashly.com

© 2010 by Ashly Audio Corporation. All rights reserved worldwide. Printed in USA 0910 R3

