

ALLEN&HEATH



DX Expander Getting Started Guide

DX32

i Before starting please check www.allen-heath.com for the latest dLive firmware and documentation.

Limited One Year Manufacturer's Warranty

Allen & Heath warrants the Allen & Heath -branded hardware product and accessories contained in the original packaging ("**Allen & Heath Product**") against defects in materials and workmanship when used in accordance with Allen & Heath's user manuals, technical specifications and other Allen & Heath product published guidelines for a period of ONE (1) YEAR from the date of original purchase by the end-user purchaser ("**Warranty Period**").

This warranty does not apply to any non-Allen & Heath branded hardware products or any software, even if packaged or sold with Allen & Heath hardware.

Please refer to the licensing agreement accompanying the software for details of your rights with respect to the use of software/firmware ("EULA").

Details of the EULA, warranty policy and other useful information can be found on the Allen & Heath website: www.allen-heath.com/legal.

Repair or replacement under the terms of the warranty does not provide right to extension or renewal of the warranty period. Repair or direct replacement of the product under the terms of this warranty may be fulfilled with functionally equivalent service exchange units.

This warranty is not transferable. This warranty will be the purchaser's sole and exclusive remedy and neither Allen & Heath nor its approved service centres shall be liable for any incidental or consequential damages or breach of any express or implied warranty of this product.

Conditions Of Warranty

The equipment has not been subject to misuse either intended or accidental, neglect, or alteration other than as described in the User Guide or Service Manual, or approved by Allen & Heath. The warranty does not cover fader wear and tear.

Any necessary adjustment, alteration or repair has been carried out by an authorised Allen & Heath distributor or agent.

The defective unit is to be returned carriage prepaid to the place of purchase, an authorised Allen & Heath distributor or agent with proof of purchase. Please discuss this with the distributor or the agent before shipping. Units returned should be packed in the original carton to avoid transit damage.

DISCLAIMER: Allen & Heath shall not be liable for the loss of any saved/stored data in products that are either repaired or replaced.

Check with your Allen & Heath distributor or agent for any additional warranty information which may apply. If further assistance is required please contact Allen & Heath Ltd.



dLive products comply with the European Electromagnetic Compatibility directive 2004/108/EC and the European Low Voltage directive 2006/95/EC.

Any changes or modifications to the product not approved by Allen & Heath could void the compliance of the product and therefore the user's authority to operate it.

dLive DX Expander Getting Started Guide

Copyright © 2015 Allen & Heath. All rights reserved.

ALLEN & HEATH

Allen & Heath Limited, Kernick Industrial Estate, Penryn, Cornwall, TR10 9LU, UK

<http://www.allen-heath.com>

IMPORTANT - Read before starting

Safety instructions

Before starting, read the **Important Safety Instructions** printed on the sheet supplied with the equipment. For your own safety and that of the operator, technical crew and performers, follow all instructions and heed all warnings printed on the sheet and on the equipment panels.

System operating firmware

The function of the DX expander is determined by the firmware (operating software) that the dLive system runs. Firmware is updated regularly as new features are added and improvements made.

① Check www.allen-heath.com for the latest version of dLive firmware.

Software licence agreement

By using this Allen & Heath product and the software within it you agree to be bound by the terms of the relevant **End User Licence Agreement** (EULA), a copy of which can be found at www.allen-heath.com/legal. You agree to be bound by the terms of the EULA by installing, copying, or using the software.

Further information

Please refer to the **Allen & Heath website** for further information, knowledgebase and technical support. For more information on dLive setup and mixing functions please refer to the dLive Firmware Reference Guide available for download at www.allen-heath.com.

① Check for the latest version of this Getting Started Guide.

You can also join our Allen & Heath Digital Community to share knowledge and information with other dLive users.

General precautions

- Protect the equipment from damage through liquid or dust contamination. Cover the expander when it is not being used for a long period.
- If the equipment has been stored in sub-zero temperatures allow time for it to reach normal operating temperature before use at the venue. Recommended operating temperature is 0 to 35 degrees Celsius.
- Avoid using the equipment in extreme heat and direct sunlight. Make sure the ventilation slots are not obstructed and that there is adequate air movement around the equipment.
- Clean the equipment with a soft brush and dry lint-free cloth. Do not use chemicals, abrasives or solvents.
- It is recommended that servicing is carried out only by an authorised Allen & Heath agent. Contact details for your local distributor can be found on the Allen & Heath website. Allen & Heath do not accept liability for damage caused by maintenance, repair or modification by unauthorised personnel.

Register your product

Register your product online at www.allen-heath.com/register.

Packed items

Check you have received the following:

- DX32 expander
- Getting Started Guide AP10242
- Safety Sheet
- IEC mains lead
- 4x M6 screws and washers for rack mounting

Contents

IMPORTANT - Read before starting	3
1. Introduction.....	5
2. Installing the Expander	6
2.1 Free standing	6
2.2 Rack mounting and flight casing.....	6
2.3 Rack ears	6
3. Front Panel	7
4. Rear Panel	8
5. I/O Modules	9
6. Connect and power up	10
6.1 MixRack connection.....	10
6.2 Surface connection	10
7. Dimensions.....	11
8. Technical specs.....	12

1. Introduction

dLive is a distributed digital mixing system providing a uniquely flexible solution for any live sound application. It separates the mix engine from the control surface, putting the audio and processing where it is needed, and offering a host of control and audio networking possibilities. Refer to the Allen & Heath website to find out more about dLive.

The **MixRack** is the heart of any dLive system. It houses the XCVI processing core complete with audio I/O, control and audio networking ports. The **Surface** is effectively a network controller for the MixRack, with the addition of built-in audio I/O and audio networking ports. The **DX Expander** adds remote, modular I/O to a dLive system. It provides 4x 8ch slots to fit a selection of analogue or digital I/O. Up to 2 DX32 Expanders can be connected to the MixRack, and a further DX32 can be connected to the Surface.

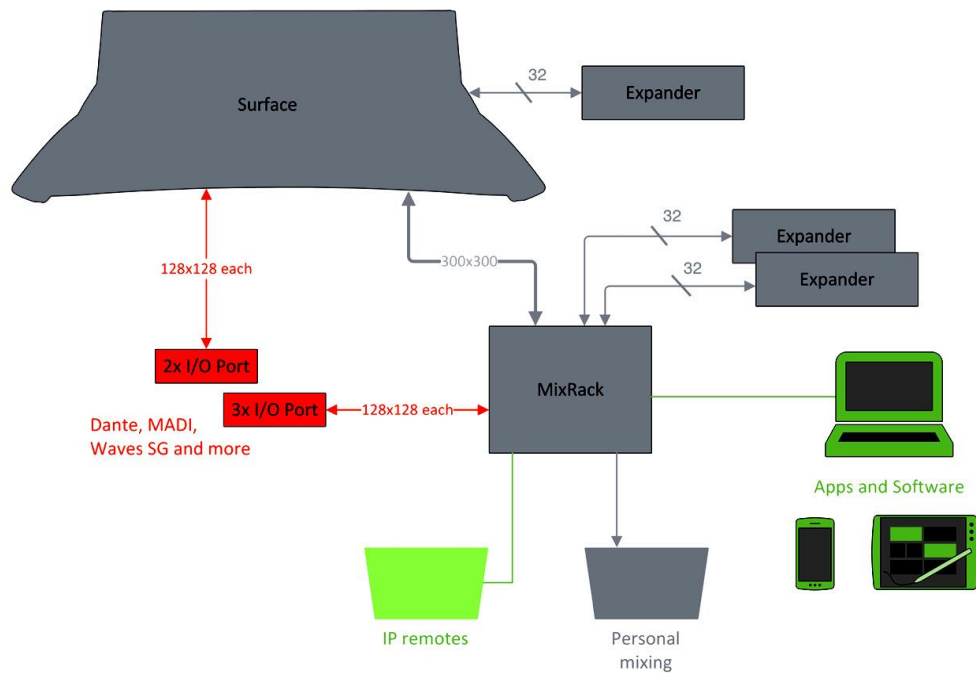

2. Installing the Expander

2.1 Free standing

The Expander can be operated as a freestanding unit for shelf or floor use. It can be operated horizontally with the connectors facing upward or sideward. Check that its plastic feet are fitted in the intended position.

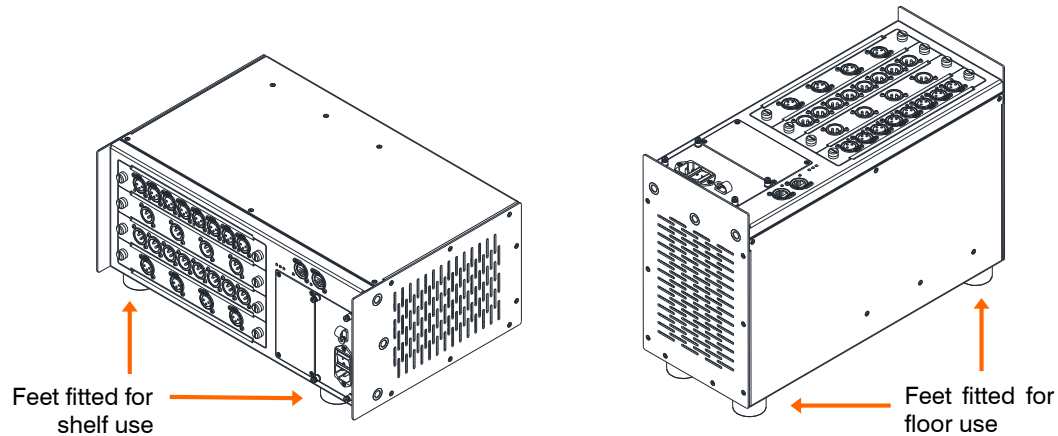

- ⓘ Ensure adequate air flow around the unit. It must not be covered in any way. Always stand the unit on a firm flat surface away from any soft furnishings or carpet.

2.2 Rack mounting and flight casing

The DX32 is designed as a 19 inch rack mount unit and occupies 4U of rack space. The plastic feet may need to be removed before rack mounting; retain them for future use.

For rental, touring and other portable use, we recommend that you use a professional grade flight case.

Use the M6 screws and washers supplied with the product to rack mount.

- ⓘ Ensure natural convection of airflow around the unit by allowing good ventilation below, in front of and behind the unit. Rack equipment known to produce a significant amount of heat should not be mounted directly below the unit. Forced convection by means of a rack mounted fan-tray may be desirable in situations where space is restricted and the ambient air temperature is high.

2.3 Rack ears

The rack ears can be detached for shelf or floor operation. They are secured to the sides of the Expander with 3 screws each as indicated below. Use a Pozidriv screwdriver to remove the rack ears.

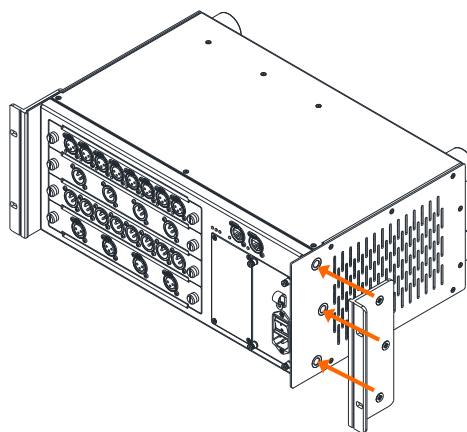

3. Front Panel

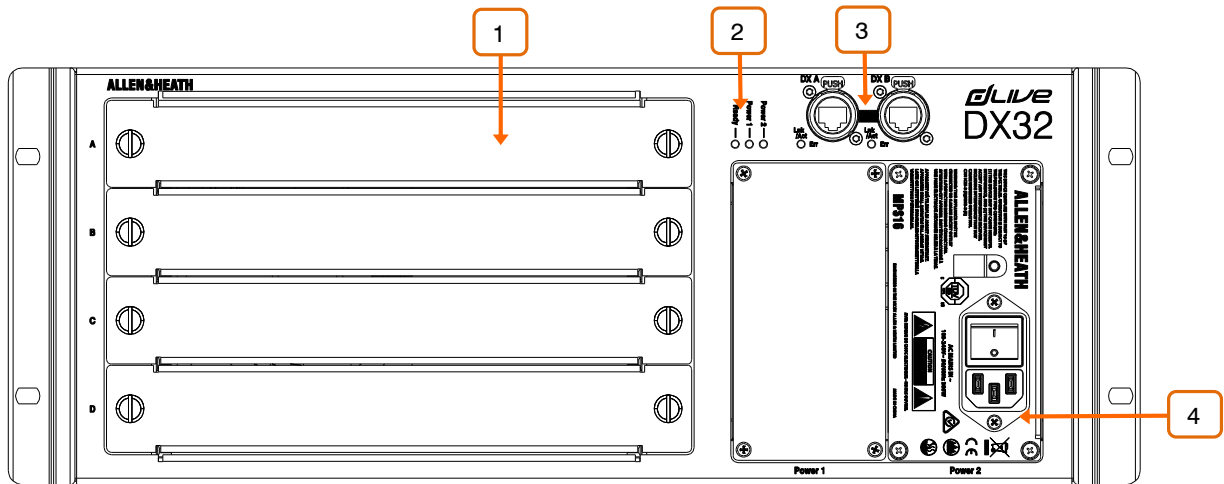

1 I/O modules – 4x slots for fitting 8ch analogue or digital I/O modules. To fit a module, switch the expander off, remove the blank panel by loosening the 2 thumb screws, slide the module into the slot and press it firmly into the mating connector, then secure it by tightening the thumb screws.

Use the dLive I/O screen to patch signals from or to the DX expander.

2 Status indicators – Power ON indicators for the 2 power supplies. The Ready indicator lights up when the output sockets are ready to pass audio after power up.

3 DX links – Dual redundant EtherCon ports for connection to a dLive MixRack or Surface over Fast Ethernet (IEEE 802.3 Layer 2 compliant). A single Cat5e (or higher) cable carries 32x32 channels of 96kHz audio and control. Use two cables for redundancy.

4 Power Supply – Hot swappable power supply with mains IEC socket and On/Off rocker switch. To remove or replace, loosen the 4 screws indicated below and slide the PSU out of the slot.

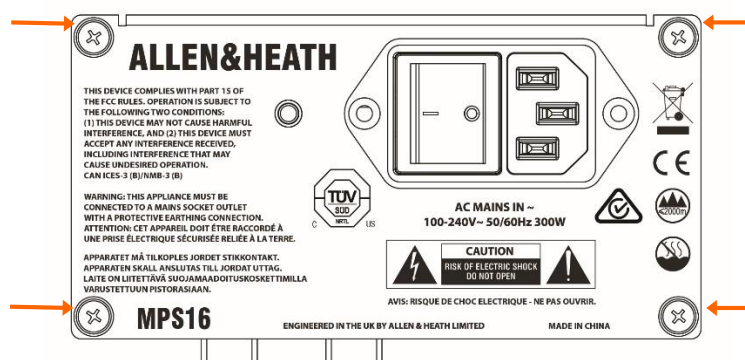

i DX Expanders ship with one PSU fitted. A second PSU can be fitted for redundancy (part number MPS-16). Remove the 4 screws securing the blank panel using a star Torx T8 screwdriver, slide the PSU into the slot, and tighten the 4 screws indicated above. The Expander will automatically switch between the supplies without interruption to the audio should one fail.

i Heed the safety warnings printed on the panel.

A plastic P-clip cable clamp is provided to secure the mains cable. Slot the cable in or lock it in place using a star Torx T20 screwdriver to refit the clamp around the cable.

4. Rear Panel

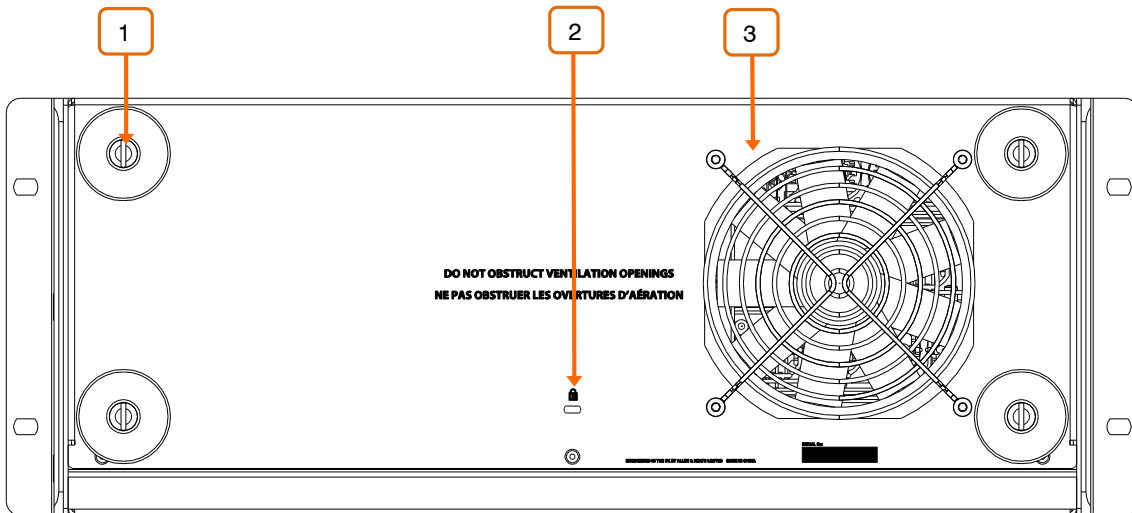

- 1 Plastic feet** – Removable plastic feet. Use a flat-head screwdriver to remove or reposition the plastic feet.
- 2 Kensington Lock** - A slot for fitting standard Kensington anti-theft security devices.
- 3 Fan** – Ultra-quiet fan. Make sure the ventilation opening is not obstructed.

5. I/O Modules

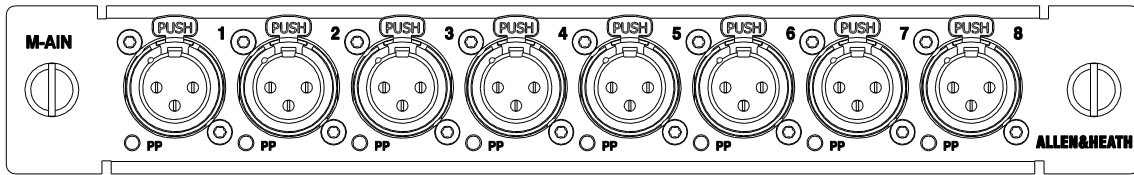

M-AIN - Recallable preamps for balanced or unbalanced microphone and line level signals. Gain, Pad and 48V are digitally controlled within the preamp. The PP indicator lights up when phantom power voltage is detected at the socket, whether internally or externally sourced.

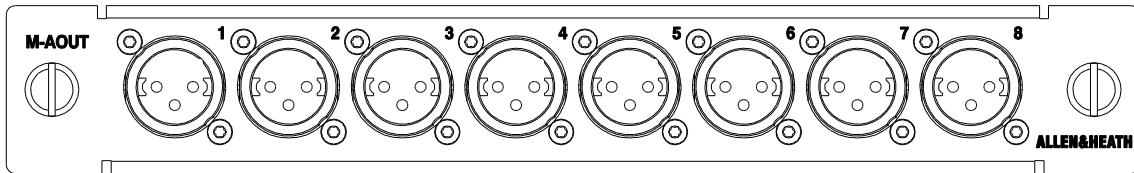

M-AOUT – Line level, balanced XLR outputs. Nominal level +4dBu. The outputs are relay protected to prevent power on or off thumps.

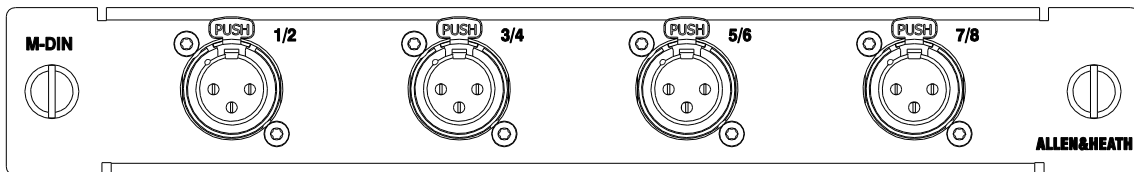

M-DIN – 4x stereo AES3 inputs with SRC (32kHz – 192kHz sampling rate). Sample Rate Conversion can be bypassed for each socket (for 96kHz operation only).

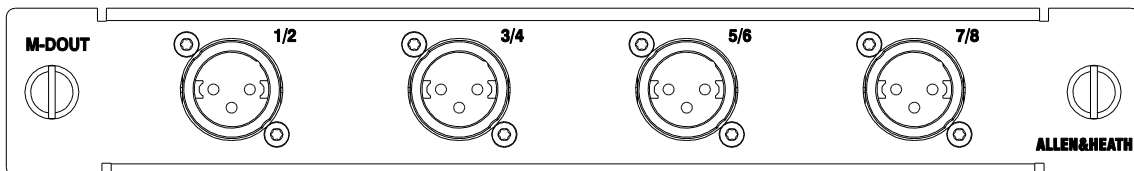

M-DOUT – 4x stereo AES3 outputs (44.1kHz, 48kHz or 96kHz switchable).

ⓘ Check www.allen-heath.com for news on available modules further than the ones listed above.

6. Connect and power up

6.1 MixRack connection

Plug a touring grade CAT5e (or higher specification) cable up to 100m long between the DX Expander and MixRack DX ports. Use two cables for redundancy if required. Use ports DX1-2 on the MixRack for the first Expander, ports DX3-4 for a second Expander.

- ⓘ Refer to www.allen-heath.com for cable requirements, recommendations, and a list of CAT5 cables available to order.

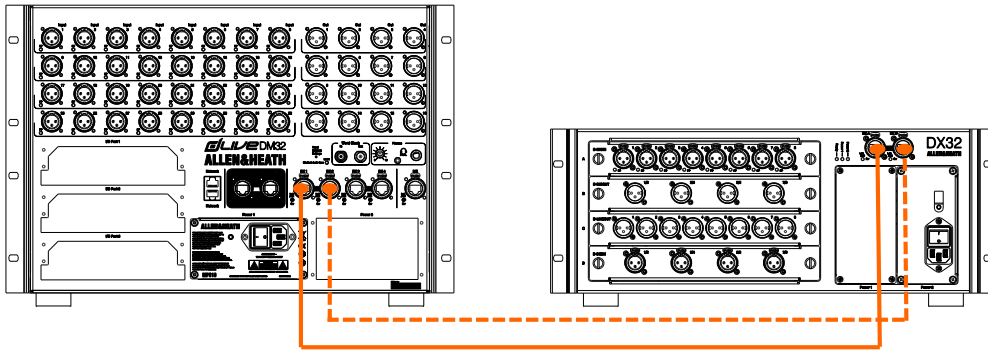

Switch on the MixRack first, then the DX Expander. The DX port Lnk/Err indicators flash at a steady rate when the link is established. The red error indicator lights if a communication error is detected. Check that the cables are correctly plugged in and are not faulty.

- ⓘ If the firmware in a connected DX Expander is not the same version as that in the dLive mixer, then the mixer will automatically update the DX firmware during power up. This takes a few seconds. During this time the Lnk/Err indicators on the DX Expander flash at a fast rate. Once updated normal flash rate is restored.

6.2 Surface connection

Plug a touring grade CAT5e (or higher specification) cable up to 100m long between the DX Expander and Surface DX ports. Use two cables for redundancy if required.

- ⓘ Refer to www.allen-heath.com for cable requirements, recommendations, and a list of CAT5 cables available to order.

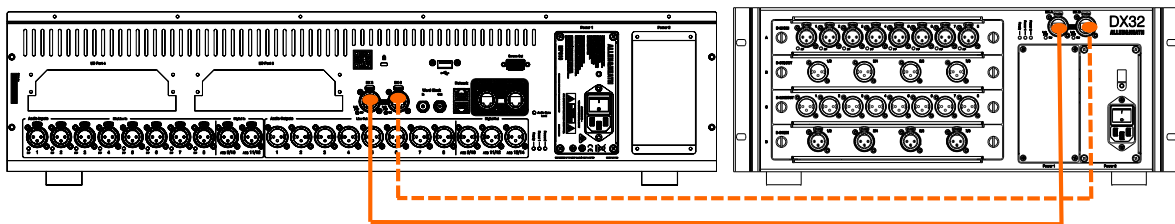

Switch on the Surface first, then the DX Expander. The DX port Lnk/Err indicators flash at a steady rate when the link is established. The red error indicator lights if a communication error is detected. Check that the cables are correctly plugged in and are not faulty.

- ⓘ If the firmware in a connected DX Expander is not the same version as that in the dLive mixer, then the mixer will automatically update the DX firmware during power up. This takes a few seconds. During this time the Lnk/Err indicators on the DX Expander flash at a fast rate. Once updated normal flash rate is restored.

7. Dimensions

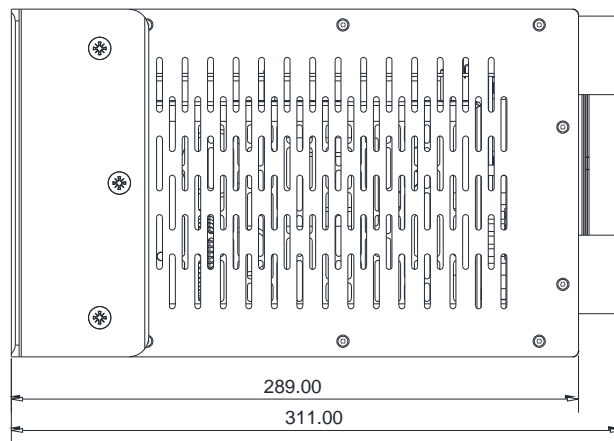
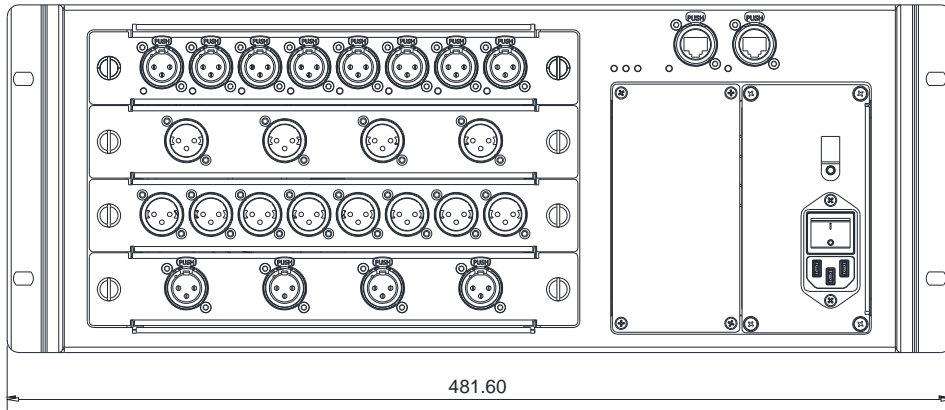
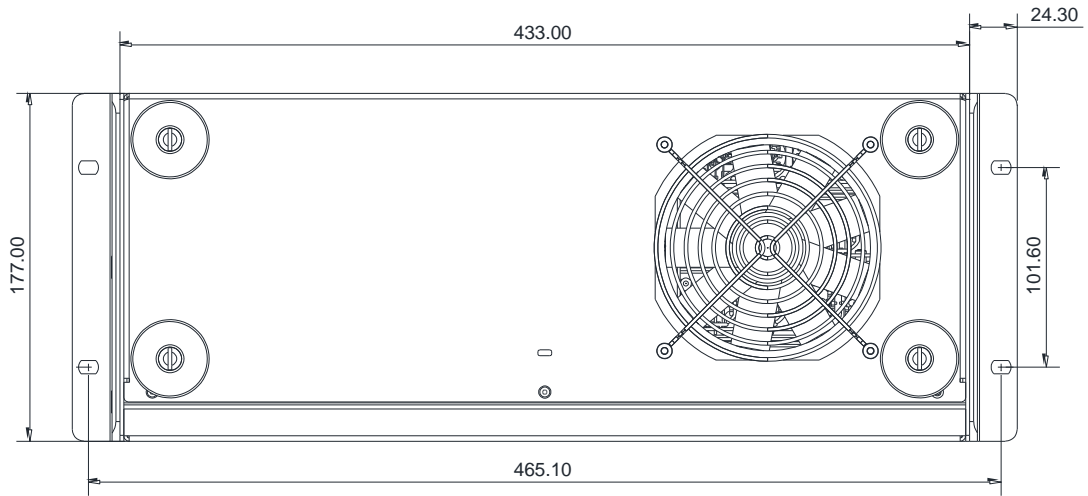

8. Technical specs

Inputs

Mic/Line XLR Inputs	Balanced XLR, +48V phantom power
Mic/Line Preamp	Fully recallable
Input Sensitivity	-60 to +15dBu
Analogue Gain	+5 to +60dB, 1dB steps
Pad	-20dB Active PAD
Maximum Input Level	+30dBu (PAD in)
Input Impedance	>4k Ω (Pad out), >10k Ω (Pad in)
Mic EIN	-127dB with 150 Ω source
Phantom Power indication	Per socket, internal or external phantom power sensing, triggered at 24V

Digital Inputs	AES3 2 Ch XLR, 2.5Vpp balanced terminated 110 Ω SRC on each pair, range 32k - 192kHz, with bypass option
-----------------------	--

Outputs

Analogue XLR Outputs	Balanced, Relay protected
Output Impedance	<75 Ω
Nominal Output	+4dBu = 0dB meter reading
Maximum Output Level	+22dBu
Residual Output Noise	-92dBu (muted, 20-20kHz) -90dBu (muted, 20-40kHz)
Digital Outputs	AES3 2 Ch XLR, 2.5Vpp balanced terminated 110 Ω 96kHz sampling rate, switchable to 48kHz, 44.1kHz

System

Sampling Rate	96kHz +/- 20 PPM
ADC	24-bit Delta-Sigma
DAC	24-bit Delta-Sigma
Latency	+ 8 samples, DX32 to Mixrack or DX32 to Surface (DX hop)
System latency	<0.6 ms (MixRack XLR in to XLR out, Input to Mix) + 5 samples, Surface to Mixrack (GigaACE hop)
Operating Temperature Range	0 deg C to 35 deg C (32 deg F to 95 deg F)
Mains Power (MPS16)	100-240V AC, 47-63Hz, 300W max

Dimensions and Weights

	Width x Depth x Height x Weight
DX32	433 x 290 x 177 mm x 10.5kg (23lbs)