



# SYSTEM 2 WAYS

## 52V2A

The 2 ways system 52V2A are composed for a pair of loudspeakers of 5", a pair of tweeters 3/4" and a pair of crossovers; projected for reproduction of frequencies in all the specter of audio. When mounted with adapters becomes ideal for installation in the original places of the automobile, being necessary no alterations in the vehicle and does have as characteristic:

- Cone in polypropylene injected with superficial treatment vacuum plating providing bold visual.
- Rubber surround with exclusive design, without mechanical brakes, allowing linear displacement and reducing distortions.
- Voice coil manufactured with copper clad aluminum wire (CCAW), body of aluminum for better transference of heat and specials resins to support high temperatures.
- Basket in steel plate with finishing in painting epoxy black color.
- Dust cap format type bullet in polypropylene vacuumforming with finishing chromed painting black onix.
- Tweeter with impedance of 4 Ohms is cooled with fluid iron, possess domo of PEI (Imida Polyether) and magnet ring of neodymium guaranteeing to the product high performance and allegiance.
- Crossover in polypropylene in black color with bold design.
- Power of 120W MAX.



52V2A

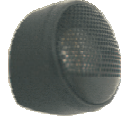

TWEETER



CROSSOVER

### SPECIFICATIONS

Nominal diameter	133 (5 1/4)	mm (in)
Nominal impedance	4	Ω
Minimum impedance @ 365 Hz.	3.94	Ω
Power handling		
MAX <sup>1</sup>	100	W
AES <sup>2</sup>	50	W
Sensitivity (2.0 V@1m) averaged from 90 to 20,000 Hz.	87	dB SPL
Power compression @ 0 dB (nom. power)	2.9	dB
Power compression @ -3 dB (nom. power)/2.	1.1	dB
Power compression @ -10 dB (nom. power)/10.	0.1	dB
Frequency response @ -10 dB	90 to 20,000	Hz

<sup>1</sup> Power handling specifications refer to normal speech and/or music program material, reproduced by an amplifier producing no more than 5% distortion. Power is calculated as true RMS voltage squared divided by the nominal impedance of the loudspeaker.  
<sup>2</sup> AES Standard (100 - 1000 Hz).

### THIELE-SMALL PARAMETERS

Fs	98	Hz
Vas	2.47 (0.087)	l (ft <sup>3</sup> )
Qts	1.10	
Qes	1.25	
Qms	3.19	
ηo (half space)	0.18	%
Sd	0.0082 (12.71)	m <sup>2</sup> (in <sup>2</sup> )
Vd (Sd x Xmax)	14.31 (0.87)	cm <sup>3</sup> (in <sup>3</sup> )
Xmax (max. excursion (peak) with 10% distortion)	1.75 (0.068)	mm (in)
Xlim (max. excursion (peak) before physical damage)	7.0 (0.27)	mm (in)

Atmospheric conditions at TS parameter measurements:

Temperature	25 (77)	°C (°F)
Atmospheric pressure	1,022	mb
Humidity	45	%

Thiele-Small parameters are measured after a 2-hour power test using half AES power. A variation of ± 17% is allowed.

### ADDITIONAL PARAMETERS

βL	3.60	Tm
Flux density	0.87	T
Voice coil diameter	31.7 (1.24)	mm (in)
Voice coil winding length	6.0 (19.68)	m (ft)
Wire temperature coefficient of resistance (α25)	0.00372	1/°C
Maximum voice coil operation temperature	190 (374)	°C (°F)
θvc (max. voice coil operation temp./max. power)	1.9 (3.74)	°C/W (°F/W)
Hvc (voice coil winding depth)	7.5 (0.29)	mm (in)
Hag (air gap height)	4.0 (0.16)	mm (in)
Re	3.7	Ω
Mms	8.2 (0.018)	g (lb)
Cms	260.0	μm/N
Rms	1.63	kg/s

### NON-LINEAR PARAMETERS

Le @ Fs (voice coil inductance @ Fs)	0.332	mH
Le @ 1 kHz (voice coil inductance @ 1 kHz)	0.173	mH
Le @ 20 kHz (voice coil inductance @ 20 kHz)	0.075	mH
Red @ Fs	0.065	Ω
Red @ 1 kHz	0.686	Ω
Red @ 20 kHz	14.13	Ω
Krm	0.1	mΩ
Kxm	2.0	mH
Erm	1.01	
Exm	0.72	

### ADDITIONAL INFORMATION

Magnet material	Barium ferrite
Magnet weight	340 (12.0) g (oz)
Magnet diameter x depth	85 x 15 (3.34 x 0.59) mm (in)
Magnetic assembly weight	680 (1.5) g (lb)
Frame material	Steel
Frame finish	Black epoxy
Voice coil material	Copper clad aluminum (CCAW)
Voice coil former material	Aluminum
Cone material	Polypropylene
Volume displaced by woofer	0.29 (0.0102) l (ft <sup>3</sup> )
Net weight	865 (1.90) g (lb)
Gross weight	2,10 (0.0046) g (lb)
Carton dimensions (W x D x H)	48 x 18 x 8.5 (18.9 x 7.0 x 3.35) cm (in)

### MOUNTING INFORMATION

Number of bolt-holes	4
Bolt-hole dimension	3.8 (0.15) and 5x7 (0.19x0.27) mm (in)
Bolt-circle diameter	120 (4.72) and 141(5.55) mm (in)
Baffle cutout diameter (front mount)	113 (4.44) mm (in)
Baffle cutout diameter (rear mount)	107 (4.21) mm (in)
Connectors	Push on terminals
Polarity	Positive voltage applied to the positive (+) terminal gives forward cone motion

Minimum clearance between the back of the magnetic assembly and the enclosure wall N/A (-) mm (in)

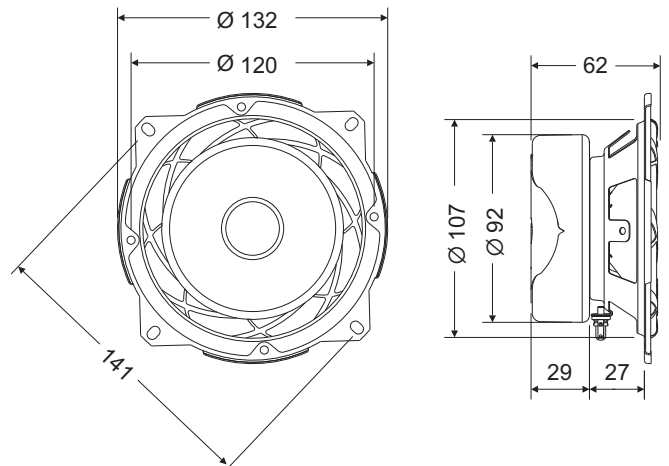

Dimensions in mm.



# SYSTEM 2 WAYS

## 52V2A

### RESPONSE CURVE (0° AND 45°) IN A TEST ENCLOSURE INSIDE ANECHOIC CHAMBER, 1W / 1 m

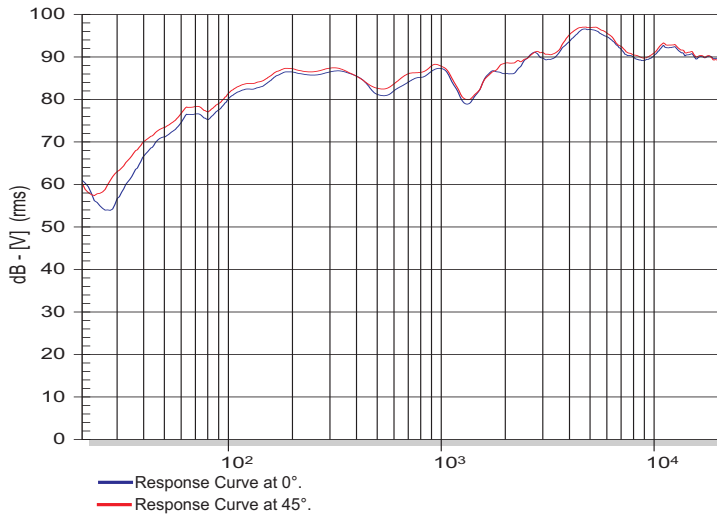

### IMPEDANCE AND PHASE CURVE MEASURED IN FREE-AIR

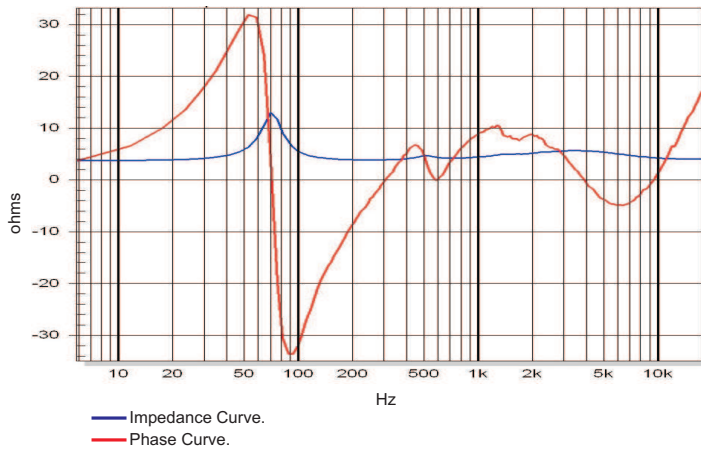

### HARMONIC DISTORTION CURVES MEASURED AT 10% AES INPUT POWER, 1 m

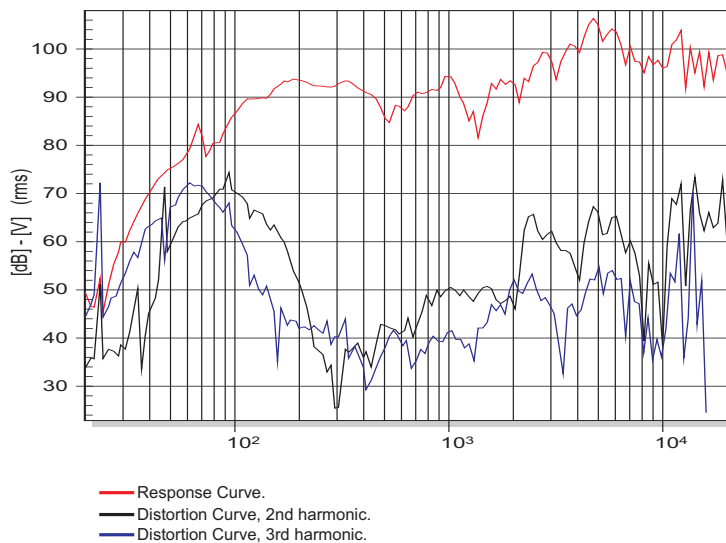

### TEST ENCLOSURE Closed box with 455 l.

### HOW TO CHOOSE THE RIGHT AMPLIFIER

The power amplifier must be able to supply twice the RMS driver power. This 3 dB headroom is necessary to handle the peaks that are common to musical programs. When the amplifier clips those peaks, high distortion arises and this may damage the transducer due to excessive heat. The use of compressors is a good practice to reduce music dynamics to safe levels.

### FINDING VOICE COIL TEMPERATURE

It is very important to avoid maximum voice coil temperature. Since moving coil resistance ( $R_E$ ) varies with temperature according to a well known law, we can calculate the temperature inside the voice coil by measuring the voice coil DC resistance:

$$T_B = T_A + \left( \frac{R_B}{R_A} - 1 \right) \left( T_A - 25 + \frac{1}{\alpha_{25}} \right)$$

$T_A, T_B$  = voice coil temperatures in °C.

$R_A, R_B$  = voice coil resistances at temperatures  $T_A$  and  $T_B$ , respectively.

$\alpha_{25}$  = voice coil wire temperature coefficient at 25 °C.

### POWER COMPRESSION

Voice coil resistance rises with temperature, which leads to efficiency reduction. Therefore, if after doubling the applied electric power to the driver we get a 2 dB rise in SPL instead of the expected 3 dB, we can say that power compression equals 1 dB. An efficient cooling system to dissipate voice coil heat is very important to reduce power compression.

### NON-LINEAR VOICE COIL PARAMETERS

Due to its close coupling with the magnetic assembly, the voice coil in electrodynamic loudspeakers is a very non-linear circuit. Using the non-linear modeling parameters  $K_{rm}, K_{xm}, E_{rm}$  and  $E_{xm}$  from an empirical model, we can calculate voice coil impedance with good accuracy.